



VZ7656R1000W / VZ7656H1000W  
Zigbee™ Wireless RTU / HP Terminal  
Equipment Controllers

## Installation Guide

For Commercial Zoning Systems

January 10<sup>th</sup>. 2012 / 028-0323-R1

---

### CONTENTS

<b>Installation</b>	<b>2</b>
Location	2
Installation	2
<b>Theory of Operation</b>	<b>3</b>
Features overview	3
Heat pump model specific features	4
<b>Wireless System Overview</b>	<b>5</b>
<b>Terminal, Identification and Function</b>	<b>6</b>
Wiring	6
Screw terminal arrangement and wiring	7
<b>Typical Applications</b>	<b>7</b>
Main outputs wiring	7
Remote sensor accessories	8
<b>Configuring and Status Display Instructions</b>	<b>9</b>
Status display	9
<b>User interface</b>	<b>11</b>
User configuration menu	11
Local keypad interface	12
<b>Installer Configuration Parameter Menu</b>	<b>17</b>
<b>Specifications</b>	<b>28</b>
<b>Drawing &amp; Dimensions</b>	<b>29</b>



# INSTALLATION

Remove the security screw on the bottom of Terminal Equipment Controller cover.

- Open unit by pulling on the bottom side of Terminal Equipment Controller (fig. 1).
- Remove wiring terminals from sticker.
- Please read the FCC ID and IC label installed in the cover upon removal of cover for the wireless products.

## Location

1. Should not be installed on an outside wall.
2. Must be installed away from any direct heat source.
3. Should not be installed near an air discharge grill.
4. Should not be affected by direct sun radiation.
5. Nothing should restrict vertical air circulation to the Terminal Equipment Controller.

## Installation

1. Swing open the Terminal Equipment Controller PCB to the left by pressing the PCB locking tabs (fig. 2).
2. Pull out cables 6" out from the wall.
3. Wall surface must be flat and clean.
4. Insert cable in the central hole of the base.
5. Align the base and mark the location of the two mounting holes on the wall. Install base in the proper orientation. Arrow on base should be facing up.
6. Install anchors in the wall.
7. Insert screws in mounting holes on each side of the base (fig. 2).
8. Gently swing back the circuit board on the base and push on it until the tabs lock it.
9. Strip each wire 1/4 inch from end.

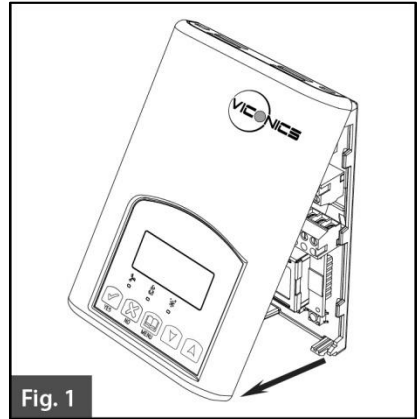

Fig. 1

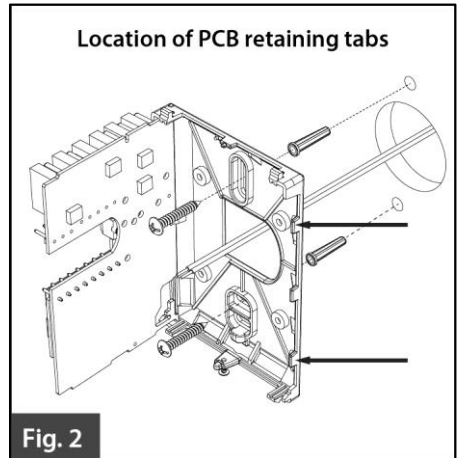

Fig. 2

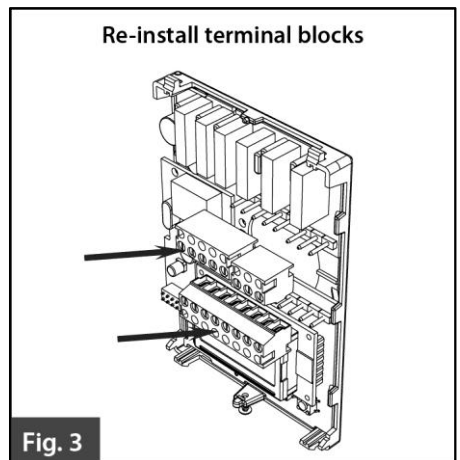

Fig. 3

10. Insert each wire according to wiring diagram.
11. Gently push excess wiring back into hole (fig. 3).
12. Re-Install wiring terminals in their correct locations (fig. 3).
13. Re-install the cover (top side first) and gently push extra wire length back into the hole in the wall.
14. Install security screw.



- When replacing an existing Terminal Equipment Controller, label the wires before removal of the Terminal Equipment Controller.
- Electronic controls are static sensitive devices. Discharge yourself properly before manipulating and installing the Terminal Equipment Controller.
- A short circuit or improper wiring may permanently damage the Terminal Equipment Controller or the equipment.
- All VT7000 series Terminal Equipment Controllers are designed for use as operating controls only and are not safety devices. These instruments have undergone rigorous tests and verification prior to shipping to ensure proper and reliable operation in the field. Whenever a control failure could lead to personal injury and or loss of property, it becomes the responsibility of the user or installer or electrical system designer to incorporate safety devices (such as relays, flow switch, thermal protections, etc...) and or an alarm system to protect the entire system against such catastrophic failures. Tampering with the devices or unintended application of the devices will result in a void of warranty.

## THEORY OF OPERATION

The VZ765 series uses a Viconics proprietary adaptive logic algorithm to control the space temperature. This algorithm controls the heating and or air conditioning system to minimize overshoot while still providing comfort. It provides exceptional accuracy due to its unique PI time proportioning control algorithm, which virtually eliminates temperature offset associated with traditional, differential-based on/off thermostats.

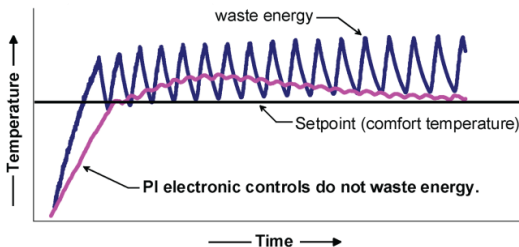

Fig.2 - On/Off mechanical control vs. PI electronic control.

## Features overview

- 7 day schedule models, 2 or 4 events.
- Supports up to 120 zones per system WITHOUT any network wires.
- Gas/oil or electric system compatibility for all type of applications.
- Rooftop Unit and Heat Pump models available.
- Remote outdoor sensing capability for added flexibility.
  - System mode heating and cooling lockout.
  - Heat pump balance point settings.
  - Zone perimeter reheat lockout.

- Remote discharge air sensor input for monitoring and control purpose.
  - System efficiency feedback.
  - Discharge high limit heating lockout.
  - Discharge low limit cooling lockout.
- Remote return air sensor input for monitoring control.
  - System efficiency feedback.
  - Return high limit heating lockout.
  - Return low limit cooling lockout.
  - Communication lost control function.
- Password protected configuration menu and lockable keypads for security.
- A configurable digital input for added flexibility. The input can be configured as the following:
  - **None:** No function will be associated with the input.
  - **Service:** a backlit flashing **Service** alarm will be displayed on the Terminal Equipment Controller LCD screen when the input is energized. It can be tied in to the AC unit control card, which provides an alarm in case of malfunction.
  - **Filter:** a backlit flashing **Filter** alarm will be displayed on the Terminal Equipment Controller LCD screen when the input is energized. It can be tied to a differential pressure switch that monitors filters.
  - **RemNSB:** remote NSB timer clock input. Will disable the internal scheduling of the Terminal Equipment Controller. The scheduling will now be set as per the digital input. The menu part related to scheduling is disabled and no longer accessible. It provides low cost setback operation via occupancy sensor or from a dry contact.
  - **RemOVR:** temporary occupancy contact. Disables all override menu function of the Terminal Equipment Controller. . The override function is now controlled by a manual remote momentarily closed contact. When configured in this mode, the input operates in a toggle mode.
  - With this function enabled it is now possible to toggle between unoccupied & occupied setpoints for the amount of time set by parameter (TOccTime) temporary occupancy time.
- Automatic smart fan operation saves energy during unoccupied periods.
- Non volatile EEPROM memory prevents loss of parameters during power shortage.
- Configurable SPST output relay on scheduling models for lighting, exhaust fan or fresh air control.
- 6 hour typical reserve time for clock in case of power loss.
- Built in 0 to 10 VDC by-pass damper / VFD output logic for static pressure control.
  - Built in static pressure loop control.
  - 0 to 5 VDC static pressure input.

### Easy configuration and self-binding operation

- Easy configuration without using any special software or additional tools.
- Can be used as stand-alone or with BACnet™ MS-TP supervision controller for monitoring purposed.
- Truly scalable in terms of supported number of zones and RTU units.

### Heat pump model specific features

- Selectable single or dual stage compressor stages
- High balance point:
  - Locks out auxiliary heating when outside air temperature is above this value.
- Low balance point:
  - Locks out heat pump compressor operation when outside air temperature is below this value.
- Compressor/auxiliary interlock:
  - Adds flexibility by locking out heat pump operation during auxiliary heating, to prevent high pressure trip when the coil is downstream of the auxiliary heat source.

# WIRELESS SYSTEM OVERVIEW

Viconics VZ72605x00W Zone Controllers are used in conjunction with the VZ7656x1000W roof top controllers. Combined, they are designed for operating typical; single or multistage RTU's and their associated local zones. For example, a typical job layout system may feature 3 RTU controllers and a total of 31 zones. This would bring to total number of nodes (individual Com addresses) to 34. RTU 1 would have 10 zones under its command, RTU 2 would have 10 zones under its command and RTU 3 would have 11 zones under its command.

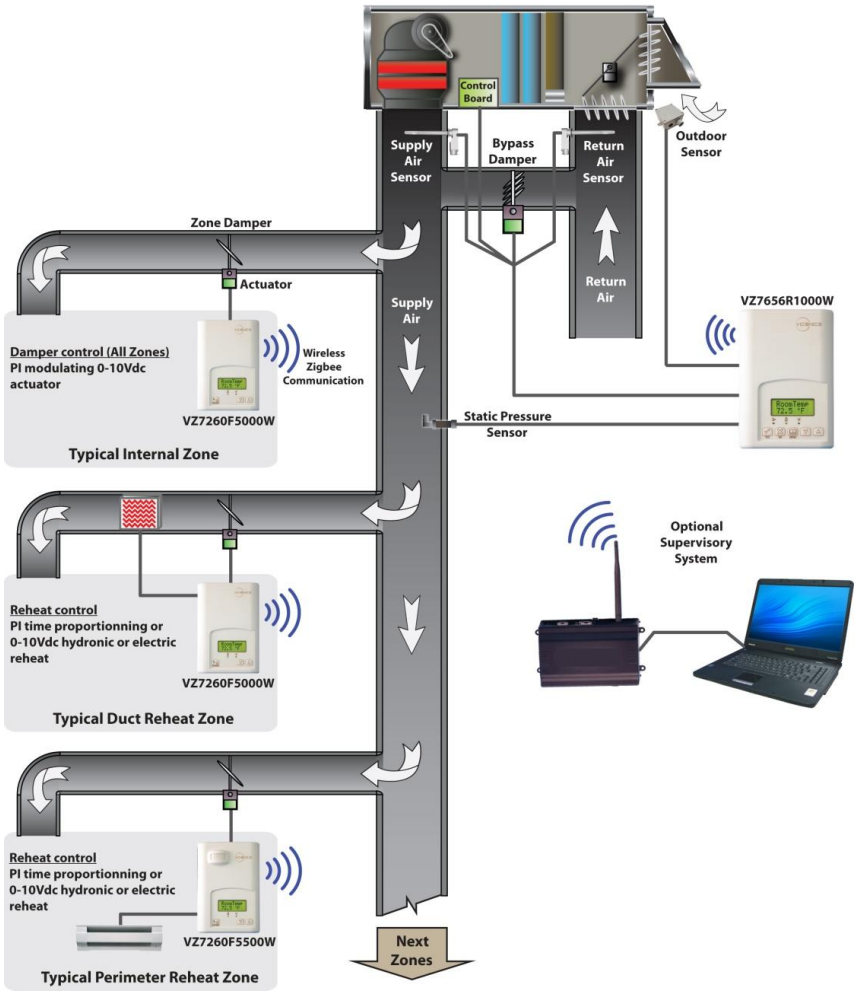

Typical Wireless Zoning System Installation

# TERMINAL, IDENTIFICATION AND FUNCTION

## Wiring

Terminal Use		Terminal Identification		Description
Rooftop	Heat pump	RTU	HP	
1 – Cool 2	Compressor 2	<b>Y2</b>		Output for cooling / compressor stage number 2.
2 – Cool 1	Compressor 1	<b>Y1</b>		Output for cooling / compressor stage number 1.
3 - Fan		<b>G</b>		Output for the fan.
4 - 24 V ~ Hot		<b>RC</b>		Power supply of controller, hot side (Delivered from the RTU).
5 - 0 V ~ Com		<b>C</b>		Power supply of controller, common side. Also used as reference for the analog BPD output when used (Delivered from the RTU).
6 – Heat Switch Leg		<b>RH</b>		24 VAC switched leg for the heating stages. <ul style="list-style-type: none"> <li>If heating stages are part of RTU, install a jumper across RC &amp; RH.</li> <li>If heating stages are part of separate equipment with a different power supply, feed external switched power leg through RH <b>without</b> installing a jumper across RC &amp; RH.</li> </ul>
7 – Heat 1		<b>W1</b>		Output for heating stage number 1.
8 –Heat 2	Reversing valve	<b>W2</b>	<b>O/B</b>	Output for heating stage number 2 for VZ7656R1000B Output for reversing valve for VZ7656H1000B
9 – By-pass damper		<b>BPD</b>		Local analog 0 - 10 VDC by-pass damper / VFD output.
10 – Aux output		<b>AU</b>		Auxiliary output used to disable economizer damper minimum position or control lighting during unoccupied periods.
11 – Static pressure		<b>SP</b>		Local analog 0 – 5 VDC static pressure input.
12 - DI1		<b>DI</b>		Configurable extra digital input. See parameter section for more information.
13 - RS		<b>RS</b>		Return air temperature sensor input. If sensor fails, controller will use the on-board thermistor sensor to control if the communication is lost.
14 - Scom		<b>Scom</b>		Reference input for DI 1, RS, OS & DS.
15 - OS		<b>OS</b>		Outside air temperature sensor input.
16 - DS		<b>DS</b>		Discharge air temperature sensor input.

# Screw terminal arrangement and wiring

VZ7656R Controller Terminals

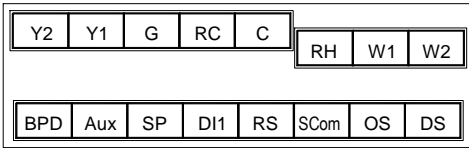

VZ7656H Controller Terminals

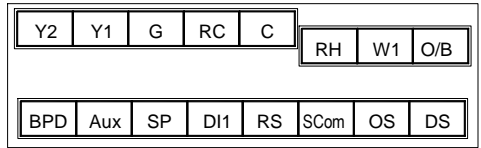

## TYPICAL APPLICATIONS

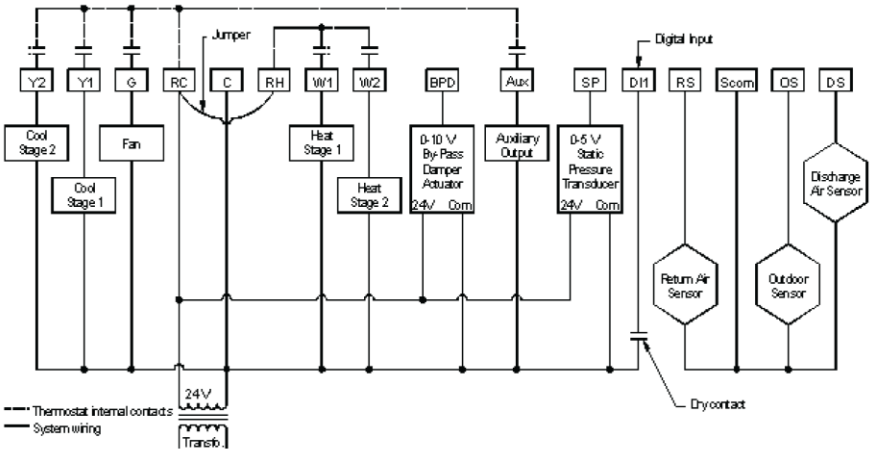

## Main outputs wiring

Wiring notes:

- Note 1: If the same power source is used for the heating stages, install jumper across RC & RH. Maximum current is 2.0 amps.
- Note 2: If auxiliary output is used to toggle occupancy of the electronic control card inside the equipment, configure the relay parameter (Aux cont) to the N.O. setting. A second relay can be added for additional functionality of the occupancy output.
- Note 3: Analog outputs and inputs use a half bridge rectifier. Reference of the control signal is the common of the power supply of the Terminal Equipment Controller. (Terminal C)
- Note 4: Electromechanical contacts are to be used with the digital inputs. Electronic triacs cannot be used as mean of switching for the input. The switched leg to the input for the input to activate is terminal C (common)
- Note 5: The transformer of the unit provides power to the Terminal Equipment Controller and the additional loads that will be wired to the Terminal Equipment Controller.

## Remote sensor accessories

Model no.	Description
S2020E1000	Outdoor temperature sensor
S2060A1000	Averaging temperature sensor
S2000D1000	Duct mounted temperature sensor

Remote mount temperature sensors use 10K NTC thermistor.

### Temperature vs. Resistance Chart for 10 Kohm NTC Thermistor

( $R_{25^{\circ}\text{C}} = 10\text{K}\Omega \pm 3\%$  -  $B_{25/85^{\circ}\text{C}} = 3975\text{K} \pm 1.5\%$ )

°C	°F	Kohm	°C	°F	Kohm	°C	°F	Kohm	°C	°F	Kohm	°C	°F	Kohm
-40	-40	324.3197	-20	-4	94.5149	0	32	32.1910	20	68	12.4601	40	104	5.3467
-39	-38	303.6427	-19	-2	89.2521	1	34	30.6120	21	70	11.9177	41	106	5.1373
-38	-36	284.4189	-18	0	84.3147	2	36	29.1197	22	72	11.4018	42	108	4.9373
-37	-35	266.5373	-17	1	79.6808	3	37	27.7088	23	73	10.9112	43	109	4.7460
-36	-33	249.8958	-16	3	75.3299	4	39	26.3744	24	75	10.4443	44	111	4.5631
-35	-31	234.4009	-15	5	71.2430	5	41	25.1119	25	77	10.0000	45	113	4.3881
-34	-29	219.9666	-14	7	67.4028	6	43	23.9172	26	79	9.5754	46	115	4.2208
-33	-27	206.5140	-13	9	63.7928	7	45	22.7861	27	81	9.1711	47	117	4.0607
-32	-26	193.9703	-12	10	60.3980	8	46	21.7151	28	82	8.7860	48	118	3.9074
-31	-24	182.2686	-11	12	57.2044	9	48	20.7004	29	84	8.4190	49	120	3.7607
-30	-22	171.3474	-10	14	54.1988	10	50	19.7390	30	86	8.0694	50	122	3.6202
-29	-20	161.1499	-9	16	51.3692	11	52	18.8277	31	88	7.7360	51	124	3.4857
-28	-18	151.6239	-8	18	48.7042	12	54	17.9636	32	90	7.4182	52	126	3.3568
-27	-17	142.7211	-7	19	46.1933	13	55	17.1440	33	91	7.1150	53	127	3.2333
-26	-15	134.3971	-6	21	43.8268	14	57	16.3665	34	93	6.8259	54	129	3.1150
-25	-13	126.6109	-5	23	41.5956	15	59	15.6286	35	95	6.5499	55	131	3.0016
-24	-11	119.3244	-4	25	39.4921	16	61	14.9280	36	97	6.2866	56	133	2.8928
-23	-9	112.5028	-3	27	37.5056	17	63	14.2629	37	99	6.0351	57	135	2.7886
-22	-8	106.1135	-2	28	35.6316	18	64	13.6310	38	100	5.7950	58	136	2.6886
-21	-6	100.1268	-1	30	33.8622	19	66	13.0307	39	102	5.5657	59	138	2.5926

**S2000D1000**; remote duct mounted temperature sensor c/w junction box.

This sensor can be used for:

- Remote return air temperature sensing with the sensor mounted on the return air duct.
- Outside air temperature sensing with the sensor installed in the fresh air plenum.
- Supply air temperature sensing.



Fig. 10 – Remote Duct Mounted Temperature Sensor



**S2060A1000**; remote averaging duct mounted temperature sensor c/w junction box.

This sensor can be used for:

- Remote averaging return air temperature sensing with the sensor mounted on the return air duct.
- Outside air temperature averaging sensing with the sensor installed in the fresh air plenum.
- Supply air temperature averaging sensor for economizer models with the sensor in the mixing plenum.

**S2020E1000**; outdoor air temperature sensor

This sensor can be used for:

- Outside air temperature sensing with the sensor installed directly exposed to the elements.
- Sensor uses a water resistant NEMA 4 ABS enclosure for outdoor applications.

### WIRING S2000D1000, S2060A1000 and S2020E1000

Remote wiring 1 sensor

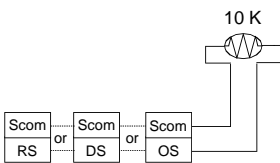

Remote wiring 4 sensors

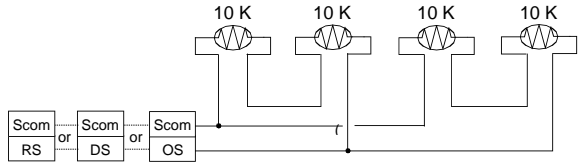

## CONFIGURING AND STATUS DISPLAY INSTRUCTIONS

### Status display

The Terminal Equipment Controller features a two-line, eight-character display. There is a low level backlight that is always active and can only be seen at night.

When left unattended, the Terminal Equipment Controller has an auto scrolling display that shows the current status of the system.

Each item is scrolled sequentially with the back light in low level mode. Pressing any key will cause the back light to come on to high level.

Manual scrolling of each menu item is achieved by pressing the Yes (scroll) key repetitively. The last item viewed will be shown on the display for 30 seconds before returning to automatic scrolling. Temperature is automatically updated when scrolling is held.

**Sequence of auto-scroll status display:**

CLOCK STATUS	SYSTEM MODE	SCHEDULE STATUS	OUTDOOR TEMPERATURE	ALARMS
Monday 12:00 AM	Sys mode auto	Occupied	Outdoor x.x °C or °F	Service
	Sys mode off	Occupied hold		DAS Alrm
	Sys mode heat	Unoccup		SetClock
	Sys mode cool			Filter
				Comm Lost

**Outdoor air temperature**

- Outdoor air temperature display is only enabled when outdoor air temperature sensor is connected.
- A maximum range status display of 50 °C (122 °F) indicates a shorted sensor. Associated functions, such as mode lockouts and economizer function are automatically disabled.
- A minimum range status -40 °C (-40 °F) is not displayed and indicates a opened sensor or a sensor not connected. Associated functions, such as mode lockouts and economizer function are automatically disabled.

**Alarms**

- If alarms are detected, they will automatically be displayed at the end of the status display scroll.
- During an alarm message display, the back lit screen will light up at the same time as the message and shut off during the rest of the status display.
- Two alarms maximum can appear at any given time.
- The priority for the alarms is as follows:

**Sequence of manual-scroll status display:**



Manual scroll of each menu item is achieved by pressing the Yes (scroll) key repetitively. The last item viewed will be shown on the display for 30 seconds before returning to automatic scrolling. Temperature is automatically updated when scrolling is held.

Clock Status	System Mode	Schedule Status	Outdoor Temperature	Alarms (if detected)
Monday 12:00 AM	Sys Mode Off	Occupied	Outdoor xx.x °C or °F	Service
	Sys Mode Auto	Unoccupied		DAS Alrm
	Sys Mode Cool	Override		SetClock
	Sys Mode Heat			Filter
				Comm Lost

Current Zone Sequence	Return Air Temperature	Discharge Air Temperature	Current Static Pressure
Zone Seq Off	RA Temp xx.x °C or °F	DA Temp xx.x °C or °F	Pressure x.x WC or Pa
Zone Seq Cool			
Zone Seq Heat			

Effective PI Heat Demand at RTU	Effective PI Cool Demand at RTU	Highest PI Heat Demand Zone Address	Highest PI Cool Demand Zone Address
Heat Out xxx %	Cool Out xxx %	Heat MAC xxx	Cool MAC xxx

<b>Service</b>	Indicates that there is a service alarm as per one of the configurable digital input (DI1 or DI2)
<b>DAS Alarm</b>	Indicates that the discharge air temperature is either too low or too high.
<b>SetClock</b>	Indicates that the clock needs to be reset. There has been a power failure which has lasted longer than 6 hours.
<b>Filter</b>	Indicates that the filters are dirty as per one of the configurable digital input (DI1 or DI2)
<b>Comm Lost</b>	The communication between devices has been lost (No Communication)

When any of the <b>fan</b> is <b>ON</b> , the <b>FAN LED</b> will illuminate	
When <b>heating</b> is <b>ON</b> , the <b>HEAT LED</b> will illuminate	
When <b>cooling</b> is <b>ON</b> , the <b>COOL LED</b> will illuminate	

## USER INTERFACE

### User configuration menu

The VZ7656X series of controllers feature an intuitive, menu-driven, back-lit LCD display that walks users and installers through the configuring steps, making the configuring process extremely simple. This menu is typically accessed by the user to set the parameters such as the clock time set, the schedule time events and the system mode.

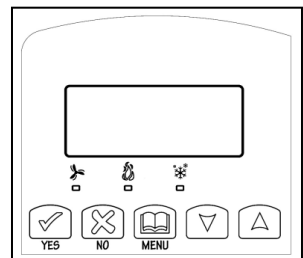

It is possible to bring up the user menu at any time by depressing the MENU key. The status display automatically resumes after exiting the user-configuring menu.

If the user pauses at any given time during configuring, **Auto Help** text is displayed to help and guide the user through the usage and configuring of the controller.





---

Ex.: Press yes key to change cooling temperature setpoint  
 Use the up or down arrow to adjust cooling setpoint

---

Each of the sections in the menu is accessed and configured using 5 keys on the controller cover. The priority for the alarms is as follows:

### Local keypad interface

	The YES key is used to confirm a selection, to move onto the next menu item and to manually scroll through the displayed information.
	The NO key is used when you do not desire a parameter change, and to advance to the next menu item. Can also be used to toggle between heating and cooling setpoints.
	The MENU key is used to access the Main User Menu or exit the menu.
	The down arrow key is used to decrease temperature setpoint and to adjust the desired values when configuring the Terminal Equipment Controller.
	The up arrow key is used to increase temperature setpoint and to adjust the desired values when configuring the Terminal Equipment Controller.

When left unattended for 45 seconds, the display will resume automatic status display scrolling.

To turn on the back light, press any key on the front panel. The back lit display will turn off automatically after 45 seconds.

#### Sequence of user menu:

<b>Override Resume</b>	<b>System mode setting</b>	<b>Schedules setting</b>	<b>Clock setting</b>
<b>Override sched Y/N</b> Appears only in unoccupied mode	<b>Sys mode set Y/N</b>	<b>Schedule set Y/N</b>	<b>Clock set Y/N</b>
<b>Cancel ovrd Y/N</b> Appears only in override mode			

#### A) Override an unoccupied period

**Override  
sched Y/N**

This menu will appear only when the controller is in unoccupied mode. The unoccupied mode is enabled either by the internal timer scheduling or by a network unoccupied command on the occupancy object.

If DI1 is configured to operate as a remote temporary override contact, this menu will be disabled.

Answering yes to this prompt will cause the all the zones attached to the RTU controller to go into occupied mode for an amount of time equal to the parameter "TOccTime" (1 to 12 hours).

## B) Resume regular scheduling

**Cancel  
ovrd Y/N**

This menu does not appear in regular operation. It will appear only when the controller is in override mode.

Answering "Yes" to this question will cause all the zones attached to the RTU controller to resume the regular configured scheduling of the RTU controller schedule.

## B) System mode setting

**Sys mode  
set Y/N**

This menu is accessed to set system mode operation. Use ▲▼ to set value, yes key to confirm.

<b>Sys mode off</b>	<b>Off mode</b> Normal cooling or heating operation disabled.
<b>Sys mode auto</b>	<b>Automatic mode</b> Automatic changeover mode between heating and cooling operation based on local zone demands voting for RTU system operation.
<b>Sys mode cool</b>	<b>Cooling mode</b> Cooling operation mode only
<b>Sys mode heat</b>	<b>Heating mode</b> Heating operation mode only
<b>Sys mode emergenc</b>	<b>Emergency heat mode</b> ( heat pump models only ) Forced auxiliary heat operation mode only

## C) Schedule set (2 events)

Scheduling can have 2 or 4 events per day. This is set in the configuration menu as per parameter; (2/4event).

**Schedule  
set Y/N**

This section of the menu permits the user to set the weekly schedule for all the zones attached to the RTU controller. Each day can be tailored to specific schedules if needed.

- 2 events can be configured per day.
- Occupied & unoccupied periods can be set for each day.

MONDAY TIMER SCHEDULE SET		TUESDAY TIMER SCHEDULE SET		WEDNESDAY TIMER SCHEDULE SET		OTHER DAYS ARE IDENTICAL
Monday set? Y/N	No next → Yes down ↓	Tuesday set? Y/N	No next → Yes down ↓	Wednesday set? Y/N	No next → Yes down ↓	Selects the day to be scheduled or modified
Yes key to access day scheduling, No key to jump to next day						
Occupied Day? Y/N	No next → Yes down ↓	Occupied Day? Y/N	No next → Yes down ↓	Occupied Day? Y/N	No next → Yes down ↓	Yes = Daily schedules will be accessed No = Unoccupied mode all day
Yes key to access day scheduling, No key to jump to next day						
		Copy Y/N Previous	Yes next → No down ↓	Copy Y/N Previous	Yes next → No down ↓	Yes = Will copy previous day schedule No = Daily schedules will be accessed
Yes key to copy previous day, No key to set new time value for each day						
Occupied 00:00 AM	Use ▲▼ To set value	Occupied 00:00 AM	Use ▲▼ To set value	Occupied 00:00 AM	Use ▲▼ To set value	Sets Event # 1 Occupied time Will activate occupied setpoints
Use ▲▼ to set value, Yes key to confirm						
Unoccup 00:00 AM	Use ▲▼ To set value	Unoccup 00:00 AM	Use ▲▼ To set value	Unoccup 00:00 AM	Use ▲▼ To set value	Sets Event # 2 Unoccupied time Will activate unoccupied setpoints

Use ▲▼ to set value, Yes key to confirm

Typical examples of a 2 event office schedule

**Ex. #1 Office building closed all weekend**

Event	Period #1 - Event #1	Period #1 - Event #2	Daily Occupancy
	<b>Occupied</b>	<b>Unoccupied</b>	<b>Daily Occupancy</b>
<b>Monday</b>	7.00 AM	6.00 PM	Day time only
<b>Tuesday</b>	7.00 AM	6.00 PM	Day time only
<b>Wednesday</b>	7.00 AM	6.00 PM	Day time only
<b>Thursday</b>	7.00 AM	6.00 PM	Day time only
<b>Friday</b>	7.00 AM	6.00 PM	Day time only
<b>Saturday</b>	12.00 PM *	12.00 PM *	Unoccupied
<b>Sunday</b>	12.00 PM *	12.00 PM *	Unoccupied

\* Configuring consecutive events to the same time will cause the controller to choose the last event as the time at which it will set its schedule. In the above example, the controller will control the unoccupied set point until 7:00 AM Monday.

**Ex. #2 Commercial building which is occupied all weekend**

Event	Period #1 - Event #1	Period #1 - Event #2	Daily Occupancy
Occupancy	Occupied	Unoccupied	
Monday	8.00 AM	5.00 PM	Day time only
Tuesday	8.00 AM	5.00 PM	Day time only
Wednesday	8.00 AM	5.00 PM	Day time only
Thursday	8.00 AM	5.00 PM	Day time only
Friday	8.00 AM	5.00 PM	Day time only
Saturday	12.00 AM **	11.59 PM **	Occupied
Sunday	12.00 AM **	11.59 PM **	Occupied

\*\*To schedule a day as occupied for 24 hours, set that day occupied time to 12:00 AM and Unoccupied time to 11:59 PM There will be a 1 minute unoccupied period every night at 11:59 PM with this schedule configuration

**D) Schedule set (4 events)**

**Schedule set Y/N**

This section of the menu permits the user to set the weekly schedule for all the zones attached to the RTU controller. Each day can be tailored to specific schedules if needed.

- 4 events can be configured per day.
- Occupied & Unoccupied periods can be set for each day.
- Scheduling the 3 rd. & 4 th. events to the same time will cancel the last period.

Monday timer Schedule set		Tuesday timer Schedule set		Wednesday timer Schedule set		Other days are identical
Monday set? Y/N	No next → Yes down ↓	Tuesday set? Y/N	No next → Yes down ↓	Wednesda set? Y/N	No next → Yes down ↓	Selects the day to be scheduled or modified
Yes key to access day scheduling, No key to jump to next day						
Occupied Day? Y/N	No next → Yes down ↓	Occupied Day? Y/N	No next → Yes down ↓	Occupied Day? Y/N	No next → Yes down ↓	Yes = Daily schedules will be accessed No = Unoccupied mode all day
Yes key to access day scheduling, No key to jump to next day						
	Copy Y/N Previous	Yes next → No down ↓	Copy Y/N Previous	Yes next → No down ↓		Yes = Will copy previous day schedule No = Daily schedules will be accessed
Yes key to copy previous day, No key to set new time value for each day						
Occupied 00:00 AM	Use ▲▼ To set value	Occupied 00:00 AM	Use ▲▼ To set value	Occupied 00:00 AM	Use ▲▼ To set value	Sets Event # 1 Occupied time Will activate occupied setpoints
Use ▲▼ to set value, Yes key to confirm						
Unoccup 00:00 AM	Use ▲▼ To set value	Unoccup 00:00 AM	Use ▲▼ To set value	Unoccup 00:00 AM	Use ▲▼ To set value	Sets Event # 2 Unoccupied time Will activate unoccupied setpoints
Use ▲▼ to set value, Yes key to confirm						
Occupie2 00:00 AM	Use ▲▼ To set value	Occupie2 00:00 AM	Use ▲▼ To set value	Occupie2 00:00 AM	Use ▲▼ To set value	Sets Event # 3 Occupied time Will activate occupied setpoints
Use ▲▼ to set value, Yes key to confirm						
Unoccup2 00:00 AM	Use ▲▼ To set value	Unoccup2 00:00 AM	Use ▲▼ To set value	Unoccup2 00:00 AM	Use ▲▼ To set value	Sets Event # 4 Unoccupied time Will activate unoccupied setpoints
Use ▲▼ to set value, Yes key to confirm						

**Ex. #1. Four event retail establishment schedule**

Event	Period 1 - Event 1		Period 1 - Event 2		Period 2 - Event 3		Period 2 - Event 4		Daily Occupancy
	Occupied		Unoccupied		Occupied		Unoccupied		
Occupancy	Cool 72°F	Heat 70°F	Cool 80°F	Heat 62°F	Cool 72°F	Heat 70 °F	Cool 80°F	Heat 62 °F	
Monday	7.00 AM		5.00 PM		12.00 PM *		12.00 PM *		Day time only
Tuesday	7.00 AM		5.00 PM		12.00 PM *		12.00 PM *		Day time only
Wednesday	7.00 AM		5.00 PM		12.00 PM *		12.00 PM *		Day time only
Thursday	7.00 AM		5.00 PM		7.00 PM		10.30 PM		Day/evening time only
Friday	7.00 AM		5.00 PM		7.00 PM		10.30 PM		Day/evening time only
Saturday	12.00 PM *		12.00 PM *		12.00 PM *		12.00 PM *		Unoccupied
Sunday	12.00 PM *		12.00 PM *		12.00 PM *		12.00 PM *		Unoccupied

\* Scheduling events to the same time will cancel the last period and leave the controller in unoccupied mode.

**E) Clock/Day Settings**



This section of the menu permits the user to set the time and day.

Time setting		Day setting		Time format setting	
Time set? Y/N	No next → Yes down ↓	Day set? Y/N	No next → Yes down ↓	12/24hrs set? Y/N	No = exit Yes down ↓
Time 0:00	Use ▲▼ To set value	Day Monday	Use ▲▼ To set value	12/24hrs 12 hrs	Use ▲▼ To set value



# INSTALLER CONFIGURATION PARAMETER MENU

- Configuration can be done through the network or locally at the Terminal Equipment Controller.
- To enter configuration, press and hold the middle button “Menu” for 8 seconds
- If a password lockout is active, “Password” is prompted. Enter password value using the “up” and “down” arrows and press “Yes” to gain access to all configuration properties of the Terminal Equipment Controller. A wrong password entered will prevent local access to the configuration menu.
- Once in the configuration menu, press the “No” button repetitively to scroll between all the available parameters.
- When the desired parameter is displayed, press “Yes” to adjust it to the desired value using “up” and “down” arrows. Once set, press “Yes” to scroll to the next parameter.

Configuration Parameters Default Value	Significance and Adjustments
<b>PswrdSet</b> Configuration parameters menu access password Default value = <b>0</b> No password prompted	This parameter sets a password access to prevent unauthorized access to the configuration menu parameters. A default value of “0” will not prompt a password or lock the access to the configuration menu. Range is: 0 to 1000
<b>RTC MAC</b> Zone Controller network address Default Value: <b>4</b>	RTC MAC address must be unique for the entire network. <b>1 to 255</b> (Increments: 1 or 10)
<b>PAN ID</b> Personal Area Network Identification Default value = 0 Range is: <b>0 to 500</b>	This parameter (Personal Area Network Identification) is used to link specific controllers to a single specific Viconics wireless gateway (VWG / Jace-Driver) or a specific VZ76 RTU controller. For every controller reporting to a VWG / Jace-Driver or VZ76 controller, be sure you set the <i>SAME</i> PAN ID value.  The default value of 0 is <b>NOT</b> a valid PAN ID. The valid range of available PAN ID is from 1 to 500.

When PAN ID is used with a range of 251 to 500, for (SA) Stand-Alone Systems

In this application, the VZ76 controller(s) are the coordinators to their own system. I.E. they are the network masters for each VZ72 controller reporting to them.

- Wireless controller factory default Channel & PAN ID = controller(s) offline
- VZ76 RTU controller is the network coordinator.
- Range of PAN ID on all controllers to use 251 to 500. This range is reserved for stand-alone system operation.

Examples:

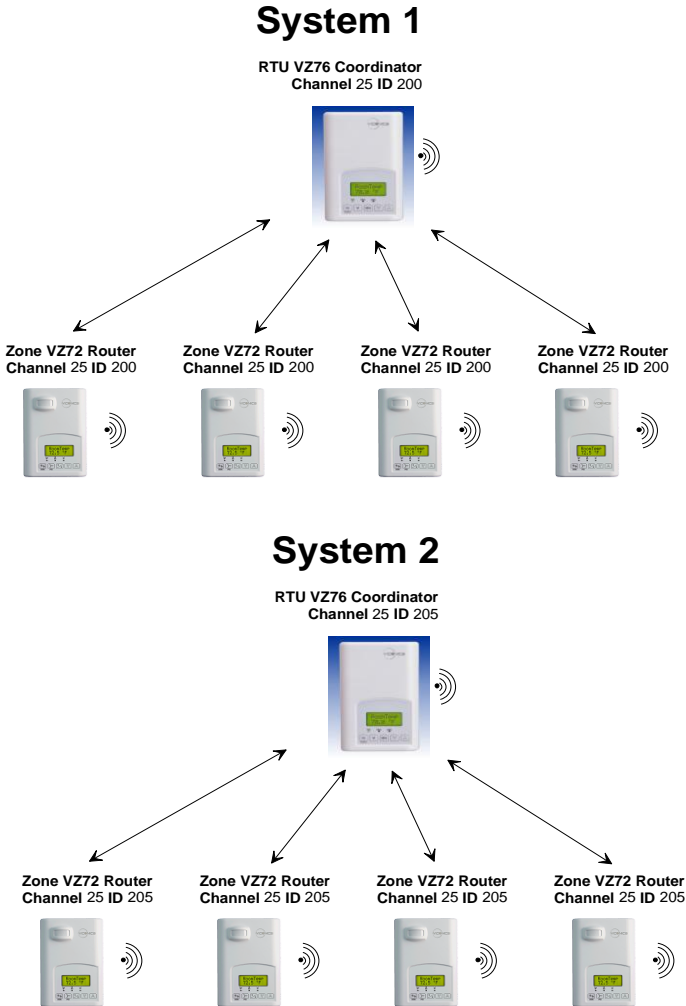

Notes:

Each system with a VZ76 RTU master will use a unique PAN ID and / or Channel settings.

When PAN ID is used with a range of 1 to 250, for (NS) Networked Systems

In this application, any controller(s) are simply router to the system. The VWG / Jace-Driver is the coordinators to the system. I.E. the VWG / Jace-Driver is the network masters for **ANY** controller(s) reporting to them.





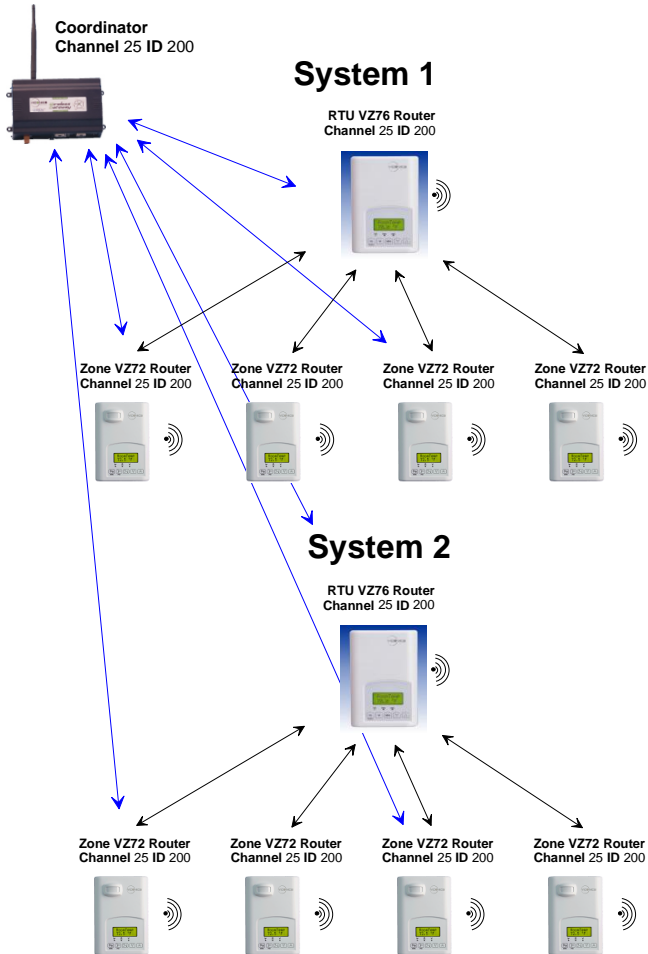







- Wireless controller factory default Channel & PAN ID = controller(s) offline
- VWG Jace-Driver is the network coordinator
- Any controllers ( VZ72's, VZ76xx RTU's or any VT7xxx wireless controllers ) act as routers.
- Range of PAN ID on all controllers to use 1 to 250. Reserved for networked system operation.

Examples:



Notes:

- Each controller(s) to use same PAN ID and Channel as VWG Jace-Driver coordinator.
- VWG / Jace-Driver supports network integration for required GUI / System / Status objects.

<b>lockout</b> Keypad lockout levels Default value = <b>0 No lock</b>		0 = No lock 1 = Low level 2 = High level		
<b>USER KEY FUNCTIONS</b>				
<b>LEVEL</b>	<b>Global Unocc. Override</b>	<b>System mode setting</b>	<b>Schedules setting</b>	<b>Clock setting</b>
<b>0</b>				
<b>1</b>				
<b>2</b>				
<b>pwr del</b> Power-up delay Default value = <b>10 seconds</b>		On initial power up of the Terminal Equipment Controller (each time 24 VAC power supply is removed & re-applied) there is a delay before any operation is authorized (fan, cooling or heating). This can be used to sequence start up multiple units and or Terminal Equipment Controller in one location.  <b>10 to 120 seconds</b>		
<b>CntrTyp</b> Sets how the Zones attached to the RTU controller vote to determine the actual system mode of operation.  (Heat or Cool)  Default Value: <b>1 = AV_H3</b>		This parameter will select the type of operation required for the RTU based on the size of the system. Please refer to the Viconics Zoning System Guide for recommended settings.  Only the Zones that actually have values above 0% in their ( <b>PIHT Wei &amp; PICL Wei</b> ) configuration parameters will be able to vote on the RTU operational mode calculation.  <b>0 =Highest:</b> The highest PI Heating or PI Cooling demand from the selected voting zones will dictate heating or cooling operation of the RTU controller.  <b>1 = AV_H3:</b> The average of the 3 highest PI Heating or PI Cooling demands from the selected voting zones will dictate heating or cooling operation of the RTU controller.  <b>2 = AV_H5:</b> The average of the 5 highest PI Heating or PI Cooling demands from the selected voting zones will dictate heating or cooling operation of the RTU controller.		
<b>Dis HL</b> Discharge air temperature high limit  Default: <b>120°F</b>		Discharge air high temperature value at which the heating stages will be locked out.  <b>70°F to 150°F (21°C to 65°C)</b> (increments: 0.5° or 5°)		

<p><b>Dis LL</b> Discharge air temperature low limit Default: <b>45°F</b></p>	<p>Discharge air low temperature value at which the cooling stages will be locked out. <b>35 to 65°F (2.0°C to 19.0°C)</b> (increments: 0.5° or 5°)</p>
<p><b>Anticycl</b> Minimum on/off operation time for stages Default value = <b>2 minutes.</b></p>	<p>Minimum On/Off operation time of cooling &amp; heating stages. <b>IMPORTANT</b>, anti-short cycling can be set to 0 minutes for equipment that possess their own anti cycling timer. Do <u>not</u> use this value unless the equipment has the above mentioned internal timer. Failure to follow this guideline may lead to damaged equipment. <b>0, 1, 2, 3, 4 &amp; 5 minutes.</b></p>
<p><b>Heat cph</b> Heating stages cycles per hour Default value = <b>4 C.P.H.</b></p>	<p>Will set the maximum number of heating stage cycles per hour under normal control operation. It represents the maximum number of cycles that the equipment will be turned on and off in the span of an hour.  Note that a higher C.P.H will represent a higher accuracy of control at the expense of wearing down mechanical components faster. <b>3, 4, 5, 6,7 &amp; 8 C.P.H.</b></p>
<p><b>Cool cph</b> Cooling stages cycles per hour Default value = <b>4 C.P.H.</b></p>	<p>Will set the maximum number of cooling stage cycles per hour under normal control operation. It represents the maximum number of cycles that the equipment will be turned on and off in the span of an hour.  Note that a higher C.P.H will represent a higher accuracy of control at the expense of wearing down mechanical components faster. <b>3 or 4 C.P.H.</b></p>
<p><b>Deadband</b> Minimum deadband Default value = <b>2.0 °F (1.1 °C)</b></p>	<p>Minimum deadband value between the heating and cooling setpoints.  Used only with the setpoints used during communication failure (ComLost Alarm) while operation is under the return air sensor. If modified, it will be applied only when any of the setpoints are modified. <b>2, 3 or 4 °F ( 1.0 to 2.0 °C )</b></p>
<p><b>Units</b> Sets the display scale of the controller Default value = <b>Imp</b></p>	<p><b>0 = SI</b> for Celsius / Pa pressure scale. <b>1 = Imp</b> for Fahrenheit / in. WC pressure scale.</p>

<p><b>fan del</b> Fan delay Default value = <b>Off</b></p>	<p>Fan delay extends fan operation by 60 seconds after the call for heating or cooling ends. Valid only for Auto fan mode. "On" fan mode will leave the fan always on. <b>Off or On</b></p>
<p><b>DI 1</b> Digital input 1 configuration Default value = <b>None</b></p>	<p>Open contact input = function not energized. Closed contact input = function energized. <b>None:</b> No function will be associated with the input. <b>Rem NSB,</b> remote NSB timer clock input. Will disable the internal scheduling of the controller. The scheduling will now be set as per the digital input. The time is still displayed as information, but the menu part related to scheduling is disabled and no longer accessible. Open contact = occupied RTU operation mode. Closed contacts = unoccupied RTU operation mode. <b>RemOVR;</b> temporary override remote contact. Disables all override menu functions of the RTU controller. The override function is now controlled by a manual remote momentarily closed contact. When configured, in this mode the input toggles between unoccupied and override. With this function enabled it is now possible to toggle between unoccupied &amp; occupied RTU operation modes for the amount of time set by the parameter "TOccTime." (Temporary occupancy time). When override is enabled, an override status message will be displayed. <b>Filter:</b> a back-lit flashing <b>filter</b> alarm will be displayed on the controller LCD screen when the input is energized. <b>Service:</b> a back-lit flashing <b>service</b> alarm will be displayed on the controller LCD screen when the input is energized.</p>
<p><b>TocTime</b> Temporary occupancy time Default value = <b>3 hours</b></p>	<p>Temporary occupancy time with occupied mode setpoints when override function is enabled When the Terminal Equipment Controller is in unoccupied mode, function is enabled with either the menu or DI1 or DI2 configured as remote override input. <b>0,1, 2, 3, 4, 5, 6, 7, 8, 9, 10, 11 &amp; 12 hours</b></p>
<p><b>Cal RS</b> Room air temperature sensor calibration Default value = <b>0.0 °F or °C</b></p>	<p>Offset that can be added/subtracted to actual displayed room temperature <b>± 5.0 °F ( ± 2.5 °C )</b></p>
<p><b>Cal OS</b> Outside air temperature sensor calibration Default value = <b>0.0 °F or °C</b></p>	<p>Offset that can be added/subtracted to actual displayed outside air temperature <b>± 5.0 °F ( ± 2.5 °C )</b></p>

<p><b>EH Mode</b>  <b>VZ7656H1000B models only</b></p> <p>Emergency Heat Mode  Default Value = <b>On</b></p>	<p>Enables or disables the Emergency Heat mode from displaying in the System mode.</p> <p><b>On:</b> The Emergenc mode is displayed in the System Mode menu</p> <p><b>Off:</b> The Emergenc mode is not displayed in the System Mode menu</p> <p><b>If the System Mode was Emergency Heat when changing this parameter from Enable to Disable, the System Mode should default back to Auto</b></p>
<p><b>HP stage</b>  <b>VZ7656H1000B models only</b></p> <p>Number of heat pump stages installed at RTU.  Default value = <b>2 stages</b></p>	<p>Will revert the operation of 2 stages controller to single stage operation when the second cooling step is not needed.</p> <p><b>1 or 2 stages</b></p>
<p><b>H stage</b>  <b>VZ7656R1000B models only</b></p> <p>Number of heating stages installed at RTU.  Default value = <b>2 stages</b></p>	<p>Will revert the operation of 2 stage controllers to a single stage when the second heating step is not needed.</p> <p><b>1 or 2 stages</b></p>
<p><b>C stage</b>  <b>VZ7656R1000B models only</b></p> <p>Number of cooling stages installed at RTU.  Default value = <b>2 stages</b></p>	<p>Will revert the operation of 2 stage controllers to a single stage when the second cooling step is not needed.</p> <p><b>1 or 2 stages</b></p>
<p><b>H lock</b>  Outside air temperature heating lockout  Default value = <b>120 °F (49 °C)</b></p>	<p>Disables heating stage operation based on outdoor air temperature.</p> <p>Function will only be enabled if OS (outside air temperature sensor) is connected.</p> <p><b>From -15 °F up to 120 °F (-26 °C up to 49 °C)</b></p>

<p><b>C lock</b>          Outside air temperature mechanical cooling lockout.          Default value = <b>-40 °F ( -40 °C )</b></p>	<p>Disables cooling stage operation based on outdoor air temperature.          On economizer model, free cooling will not be disabled by this function.          Function will only be enabled if OS (outside air temperature sensor) is connected.  <b>From -40 °F up to 95 °F ( -40 °C up to 35 °C )</b></p>									
<p><b>2/4event</b>          Number of events configuration          Default value = <b>2 event</b></p>	<p><b>2 events</b>, will set up scheduling for the following          Event 1 is for Occupied setpoints          Event 2 is for Unoccupied setpoints  <b>4 events</b>, will set up scheduling for the following          Event 1 is for Occupied setpoints          Event 2 is for Unoccupied setpoints          Event 3 is for Occupied setpoints          Event 4 is for Unoccupied setpoints</p>									
<p><b>aux cont</b>          Auxiliary contact configuration          Default value = <b>N.O. normally open</b></p>	<p>This contact can be used to energize peripheral devices such as: lighting equipment, exhaust fans, economizers, etc.          This contact will operate in parallel with the internal occupied/unoccupied schedule of the Terminal Equipment Controller or the remote NSB contact if DI1 or DI2 is used.          When the system is in <b>OFF mode</b>, the contact will remain in its unoccupied status independently of the occupied / unoccupied schedule.</p> <table border="1" data-bbox="359 764 993 878"> <thead> <tr> <th data-bbox="359 764 524 816">Configured</th> <th data-bbox="524 764 745 816">Contact occupied status</th> <th data-bbox="745 764 993 816">Contact unoccupied status</th> </tr> </thead> <tbody> <tr> <td data-bbox="359 816 524 846"><b>N.O.</b></td> <td data-bbox="524 816 745 846">Closed</td> <td data-bbox="745 816 993 846">Opened</td> </tr> <tr> <td data-bbox="359 846 524 878"><b>N.C.</b></td> <td data-bbox="524 846 745 878">opened</td> <td data-bbox="745 846 993 878">Closed</td> </tr> </tbody> </table>	Configured	Contact occupied status	Contact unoccupied status	<b>N.O.</b>	Closed	Opened	<b>N.C.</b>	opened	Closed
Configured	Contact occupied status	Contact unoccupied status								
<b>N.O.</b>	Closed	Opened								
<b>N.C.</b>	opened	Closed								



<p><b>Prog rec</b> Progressive recovery enabled</p> <p>Default value = <b>Off</b></p> <p>Progressive recovery is automatically disabled if BI 1 is configured remote NSB</p>	<p><b>Off</b>, = no progressive recovery.</p> <p>The configured occupied schedule time is the time at which the system will restart and send the occupied status to the attached zones.</p> <p><b>On</b>, = progressive recovery active.</p> <p>The configured occupied schedule time is the time at which the desired occupied temperature setpoints will be attained at the Zones. The RTU controller will automatically optimize the equipment start time.</p>
<p><b>Occ CL</b> Return air sensor network lost occupied cooling setpoint</p> <p>Default: <b>75°F</b></p>	<p>If network communication is lost with the zone controllers, the return air sensor will control the RTC to maintain this setpoint.</p> <p><b>54°F to 100°F (12°C to 37.5°C)</b> (increments: 0.5° or 5°)</p>
<p><b>Occ HT</b> Return air sensor network lost occupied heating setpoint</p> <p>Default: <b>72°F</b></p>	<p>If network communication is lost with the zone controllers, the return air sensor will control the RTC to maintain this setpoint.</p> <p><b>40 to 90°F (4.5°C to 32°C)</b> (increments: 0.5° or 5°)</p>
<p><b>Unocc CL</b> Return air sensor network lost unoccupied cooling setpoint</p> <p>Default: <b>82°F</b></p>	<p>If network communication is lost with the zone controllers, the return air sensor will control the RTC to maintain this setpoint.</p> <p><b>54 to 100°F (12°C to 37.5°C)</b> (increments: 0.5° or 5°)</p>
<p><b>Unocc HT</b> Return air sensor network lost unoccupied heating setpoint</p> <p>Default: <b>65°F</b></p>	<p>If network communication is lost with the zone controllers, the return air sensor will control the RTC to maintain this setpoint.</p> <p><b>40 to 90°F (4.5°C to 32°C)</b> (increments: 0.5° or 5°)</p>
<p><b>Sp range</b> Static Pressure sensor range</p> <p>Default: <b>0</b></p>	<p>Static pressure transducer range. Voltage input range is 0 to 5 VDC.</p> <p><b>0 = 0 to 1.5 in WC</b> <b>1 = 0 to 2 in WC</b> <b>2 = 0 to 3 in WC</b> <b>3 = 0 to 4 in WC</b> <b>4 = 0 to 5 in WC</b></p>

<p><b>Pressure</b></p> <p>Static Pressure setpoint</p> <p>Default: <b>0.8"WC</b></p>	<p>Bypass damper will maintain this supply static pressure set point.</p> <p>Please refer to the Viconics Zoning System Guide for recommended settings.</p> <p><b>0 to 2 in WC (0 Pa to 500 Pa)</b> (increments: 0.1" WC or 25 Pa)</p>
<p><b>SP Cntrl</b></p> <p>Static Pressure Control Type</p> <p>Default: <b>BPD</b></p>	<p>Depending on the setting of this parameter, the 0-10VDC pressure control output (labeled BPD) will either have a 0VDC or 10VDC output when the fan is Off.</p> <p><b>BPD (By-Pass Damper): 10VDC when fan is Off</b></p> <p><b>FD (Variable Frequency Drive): 0VDC when fan is Off</b></p>
<p><b>Parameters Specific to the VZ7656H1000B Heat Pump Model</b></p>	
<p><b>High BP</b></p> <p>High balance point</p> <p>Default value = <b>90 °F ( 32.0 °C )</b></p> <p>Function will only be enabled if OS (outside air temperature sensor) is connected.</p>	<p>In <i>Heating or Auto mode</i>, it is the outside air temperature value at which the auxiliary heat will be cut off. Above that value, only the heat pump will be used to maintain the heating setpoint</p> <p><b>34 to 90 °F ( 1.0 to 32.0 °C )</b></p>
<p><b>Low BP</b></p> <p>Low balance point</p> <p>Default value = <b>-40 °F ( -40 °C )</b></p> <p>Function will only be enabled if OS (outside air temperature sensor) is connected.</p>	<p>In <i>Heating, Cooling or Auto mode</i>, it is the outside air temperature value at which the heat pump operation will be cut off. Below that value, only the auxiliary heat will be used to maintain the heating setpoint</p> <p><b>-40 to 30 °F ( -40 to -1.0 °C )</b></p>
<p><b>Re valve</b></p> <p>Reversing valve operation O/B</p> <p>Default value = <b>O</b></p>	<p>Heat pump reversing valve operation</p> <p><b>O</b> will energize the valve in cooling operation.</p> <p><b>B</b> will energize the valve in heating operation.</p>

<p><b>Comp/aux</b></p> <p>Compressor/auxiliary interlock</p> <p>Default value = <b>Off</b></p>	<p>Sets the operation and interaction mode of the heat pump with the auxiliary heat.</p> <p><b>Interlock Off.</b> In <i>Heating mode</i>.</p> <p>If the heat pump is not able to satisfy the heating setpoint, the auxiliary heat will be energized at the same time as the heat pump stage. Typically applies when the air handler heat pump coil is installed before the auxiliary heat. ( all electric systems )</p> <p><b>Interlock On.</b> In <i>Heating mode</i>.</p> <p>If the heat pump is not able to satisfy the heating setpoint, the auxiliary heat will be energized and the heat pump will be cut off. Typically applies when the air handler heat pump coil is installed after the auxiliary heat. ( add on systems ) There is a 2 minute delay to restart the heat pump, when the auxiliary heat is shut down.</p>
--	--

# SPECIFICATIONS

## Terminal Equipment Controller power

<b>requirements:</b> .....	19-30 VAC 50 or 60 Hz; 2 VA Class 2 RC to RH jumper 2.0 Amps 48VA max.
<b>Operating conditions:</b> .....	0 °C to 50 °C ( 32 °F to 122 °F ) 0% to 95% R.H. non-condensing
<b>Storage conditions:</b> .....	-30 °C to 50 °C ( -22 °F to 122 °F ) 0% to 95% R.H. non-condensing
<b>Sensor:</b> .....	Local 10 K NTC thermistor
<b>Resolution:</b> .....	± 0.1 °C ( ± 0.2 °F )
<b>Temperature control accuracy:</b> .....	± 0.5 °C ( ± 0.9 °F ) @ 21 °C ( 70 °F ) typical calibrated
<b>Contact output rating</b> .....	Relay output: 30 VAC, 1 Amp. Maximum, 3 Amp. In-rush.
<b>Occ, Stand-By and Unocc cooling setpoint range:</b> .....	12.0 to 37.5 °C ( 54 to 100 °F )
<b>Occ, Stand-By and Unocc heating setpoint range:</b> .....	4.5 °C to 32 °C ( 40 °F to 90 °F )
<b>Room and outdoor air temperature display range:</b> .....	-40 °C to 50 °C ( -40 °F to 122 °F )
<b>Digital inputs:</b> .....	Dry contact across terminal D11
<b>By-pass damper/VFD analog output rating</b> .....	0 to 10 VDC into 2KΩ resistance min
<b>By-pass damper /VFD analog output accuracy:</b> .....	± 3% typical
<b>Wire gauge:</b> .....	18 gauge maximum, 22 gauge
<b>Approximate shipping weight:</b> .....	0.75 lb ( 0.34 kg )
<b>Agency Approvals all models:</b> .....	<b>UL:</b> UL 873 (US) and CSA C22.2 No. 24 (Canada), File E27734 with CCN XAPX (US) and XAPX7 (Canada) <b>Industry Canada:</b> ICES-003 (Canada) <b>FCC:</b> Compliant to CFR 47, Part 15, Subpart B, Class A (US) <b>CE :</b> EMC Directive 2004/108/EC (Europe Union) <b>C-Tick:</b> AS/NZS CISPR 22 Compliant (Australia / New Zealand) Supplier Code Number N10696
<b>Agency Approvals all models:</b> .....	<b>FCC:</b> Compliant to: Part 15, Subpart B, Class (US)
<b>Agency Approvals Wireless models:</b> .....	

THIS DEVICE COMPLIES WITH PART 15 OF THE FCC RULES. OPERATION IS SUBJECT TO THE FOLLOWING TWO CONDITIONS: (1) THIS DEVICE MAY NOT CAUSE HARMFUL INTERFERENCE, AND (2) THIS DEVICE MUST ACCEPT ANY INTERFERENCE RECEIVED, INCLUDING INTERFERENCE THAT MAY CAUSE UNDESIRE OPERATION



Please check with your local government for instruction on disposal of this product

# DRAWING & DIMENSIONS

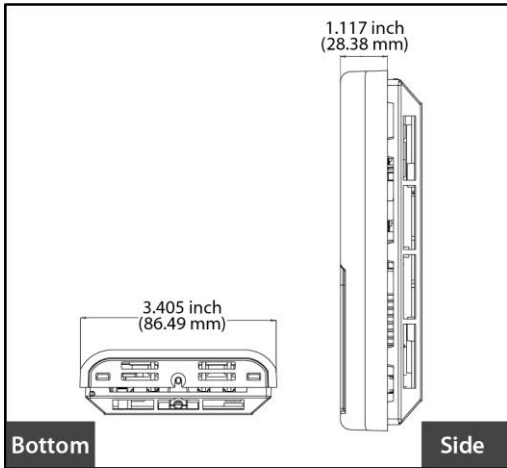
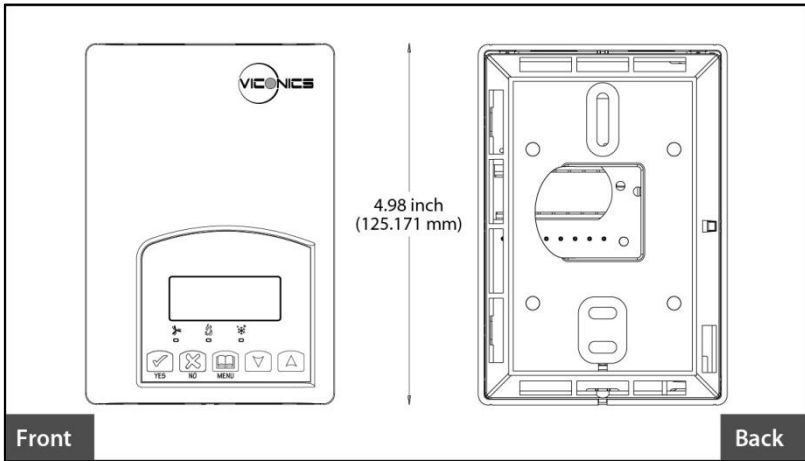

Viconics Technologies Inc.  
9245 Langelier Blvd. | St-Leonard | Quebec | Canada | H1P 3K9  
Tel.: (514) 321.5660 | Fax: (514) 321.4150 Toll free: 1 800.563.5660  
sales@viconics.com | [www.viconics.com](http://www.viconics.com)