



Installation, Start-Up, and Service Instructions

CONTENTS

SAFETY CONSIDERATIONS	1
GENERAL	1, 2
INSTALLATION	2-17
Step 1 — Receive and Inspect Unit	2
Step 2 — Protect Unit from Damage	2
Step 3 — Provide Unit Support	2
Step 4 — Rig and Place Unit	8
Step 5 — Make Condensate Piping Connections	8
Step 6 — Install Ductwork	8
Step 7 — Split Systems (Factory Option, if Required)	8
Step 8 — Make Electrical Connections	10
• FIELD CONTROL WIRING	
• THERMOSTAT WIRE	
Step 9 — Adjust Fan Speed	10
START-UP	17
SERVICE	17,18

SAFETY CONSIDERATIONS

Installing and servicing air-conditioning equipment can be hazardous due to system pressure and electrical components. Only trained and qualified service personnel should install, repair, or service air-conditioning equipment.

Untrained personnel can perform basic maintenance functions such as cleaning coils and filters and replacing filters. All other operations should be performed by trained service personnel. When working on air-conditioning equipment, observe precautions in the literature and on tags and labels attached to unit.

Follow all safety codes. Wear safety glasses and work gloves. Use quenching cloth for unbrazing operations. Have fire extinguisher available.

⚠ WARNING

Disconnect all power to the unit before performing maintenance or service. Electrical shock and personal injury could result.

NOTE: Ensure voltage on unit agrees with voltage listed on the unit rating plate.

⚠ WARNING

DO NOT USE TORCH to remove any component. System contains oil and refrigerant under pressure.

To remove a component, wear protective gloves and goggles and proceed as follows:

- a. Shut off electrical power to unit.
- b. Recover refrigerant to relieve all pressure from system using both high-pressure and low pressure ports.
- c. Traces of vapor should be displaced with nitrogen and the work area should be well ventilated. Refrigerant in contact with an open flame produces toxic gases.
- d. Cut component connection tubing with tubing cutter and remove component from unit. Use a pan to catch any oil that may come out of the lines and as a gage for how much oil to add to the system.
- e. Carefully unsweat remaining tubing stubs when necessary. Oil can ignite when exposed to torch flame.

Failure to follow these procedures may result in personal injury or death.

⚠ CAUTION

DO NOT re-use compressor oil or any oil that has been exposed to the atmosphere. Dispose of oil per local codes and regulations. **DO NOT** leave refrigerant system open to air any longer than the actual time required to service the equipment. Seal circuits being serviced and charge with dry nitrogen to prevent oil contamination when timely repairs cannot be completed. Failure to follow these procedures may result in damage to equipment.

GENERAL

The 50AH024-096 units are single-package, indoor, horizontally mounted air conditioners of 2 to 8 tons capacity. The 50AH units are ASHRAE (American Society of Heating, Refrigerating and Air Conditioning Engineers) 90.1 compliant.

These units can be mounted as factory-shipped single-package units or can be separated and mounted as a split system. If unit is split, the condensing section must be mounted horizontally.

All units are designed to be ducted on both the condenser and evaporator sides. Centrifugal blowers are used to ensure quiet air delivery to the conditioned space. Sound level requirements should be determined before final unit installation site is chosen.

Unit servicing is relatively simple since access to the condenser and evaporator motors, blowers, belt, and pulley is gained through access panels located on the sides of the unit. These panels may also be used for cleaning of condenser coils. Unit side panels also provide access to control box and pressure switches.

Refrigeration cycle components (e.g., compressor, filter drier, etc.) can be serviced upon removal of the base unit from the space.

INSTALLATION

⚠ WARNING

Determine building alterations required to run piping, wiring, and ductwork. Follow dimensional drawings carefully for ductwork, piping locations, electrical wiring, and overall unit dimensions. Read all installation instructions before starting installation.

The 50AH units are intended for indoor installation only.

Step 1 — Receive and Inspect Unit — Unpack and check unit against shipping order. See Fig. 1 for model number nomenclature. Inspect carefully for concealed shipping damage. *If unit is damaged or incomplete, file claim with transportation company and advise Carrier immediately.*

Step 2 — Protect Unit from Damage — To maintain warranty, unit must be protected against theft and vandalism and stored indoors at all times.

Step 3 — Provide Unit Support — Refer to Fig. 2-5 for unit dimensions. Refer to Table 1 for unit sizes and weights.

Each unit requires the following field-supplied items:

- 8 — threaded suspension rods (³/₈-in.-16 SAE Grade 1 minimum), 4 additional rods are needed if the unit has a factory-installed air-side economizer
- 8 — washers
- 8 — locknuts

Install the 8 field-supplied rods by suspending them from a suitable ceiling support. Locate rods to mate with 8 outside corner rigging holes shown in Fig. 2-5. Unit center of gravity is shown in Fig. 6.

The ceiling and ceiling supports of existing buildings may require reinforcements; follow all applicable codes.

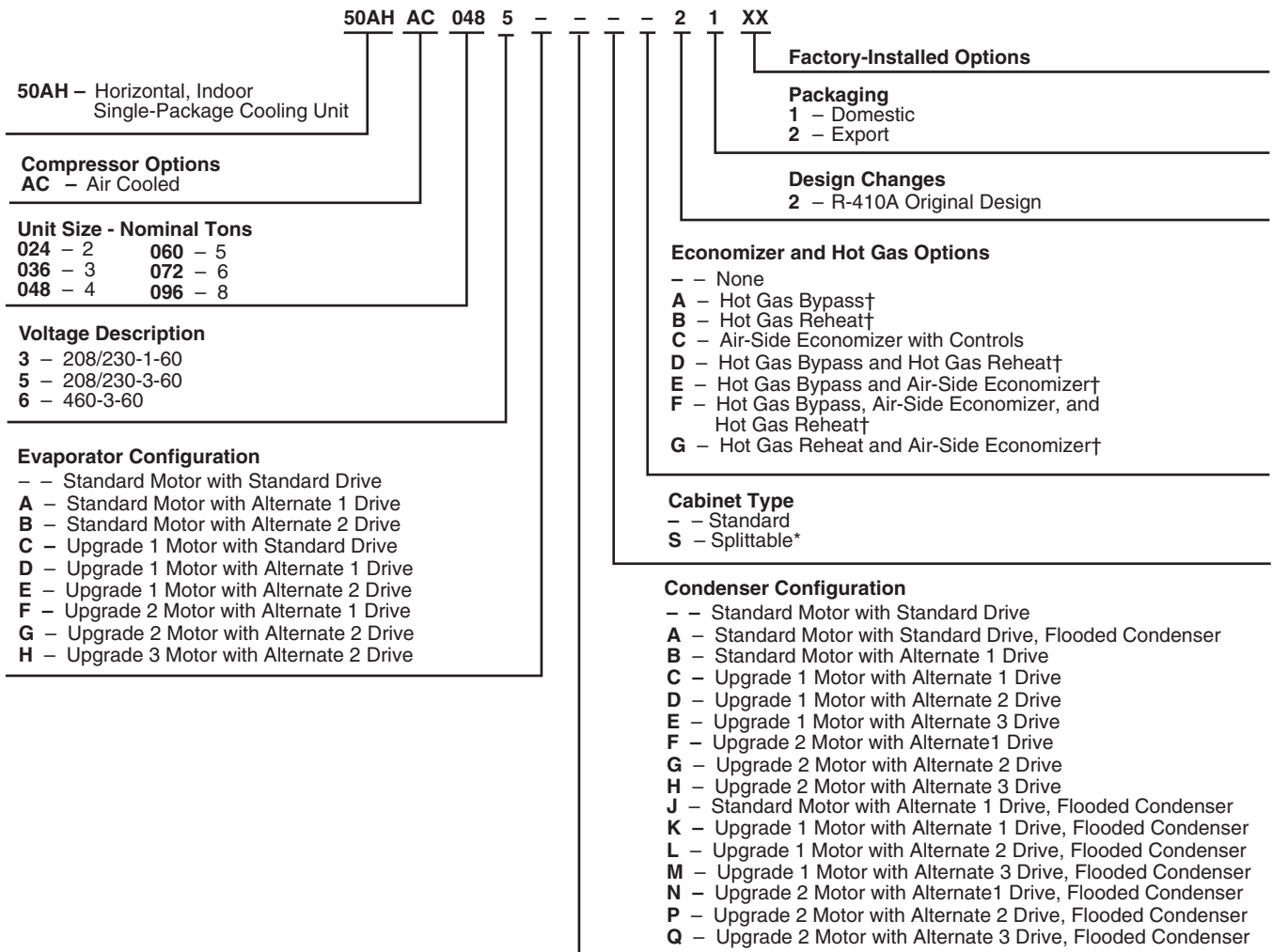

* Includes interconnecting kit and electrical box.
 †Not available with splittable units.

Fig. 1 — Model Number Nomenclature

OPERATING WEIGHT DISTRIBUTION

UNIT	WEIGHT OF CORNER (lb)							
	A	B	C	D	E	F	G	H
50AH								
024	87	111	88	113	143	136	105	100
036	87	111	89	114	144	138	106	101
048	91	116	92	118	152	145	111	106
060	91	117	93	119	153	146	112	107

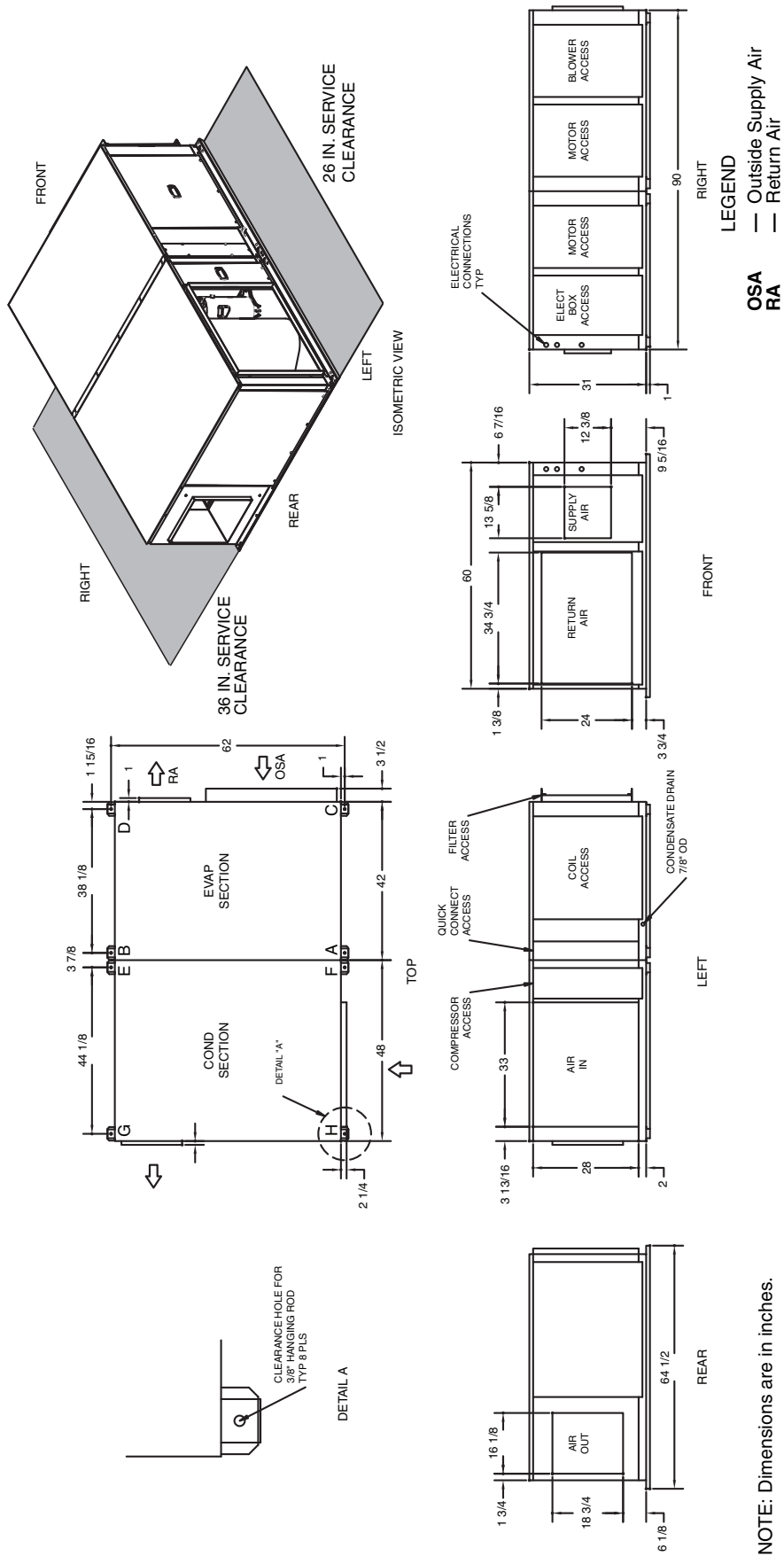

NOTE: Dimensions are in inches.

Fig. 2 — Unit Dimensions — 50AH024-060 Standard Units

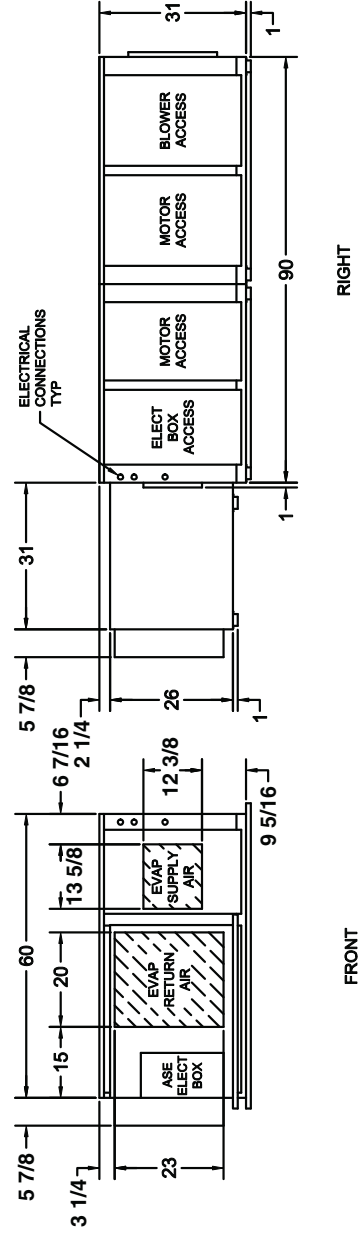
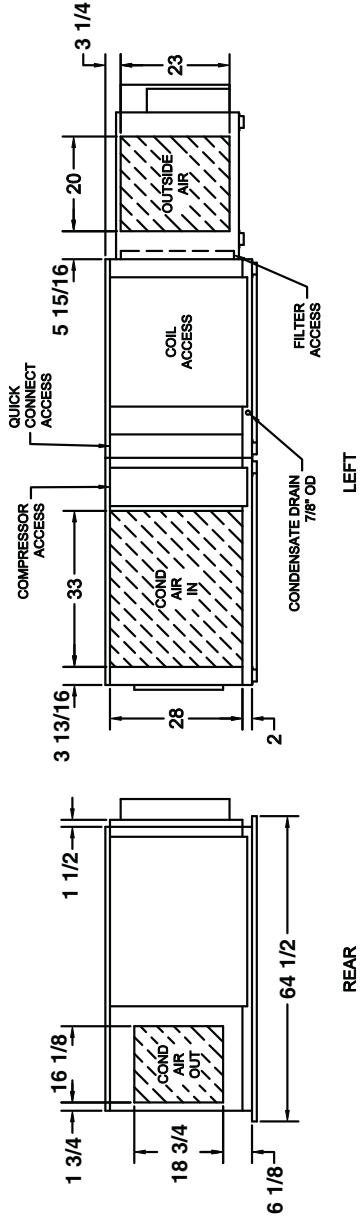
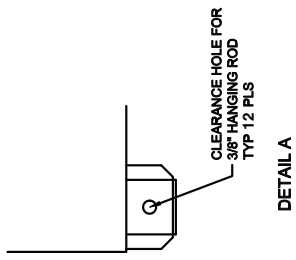
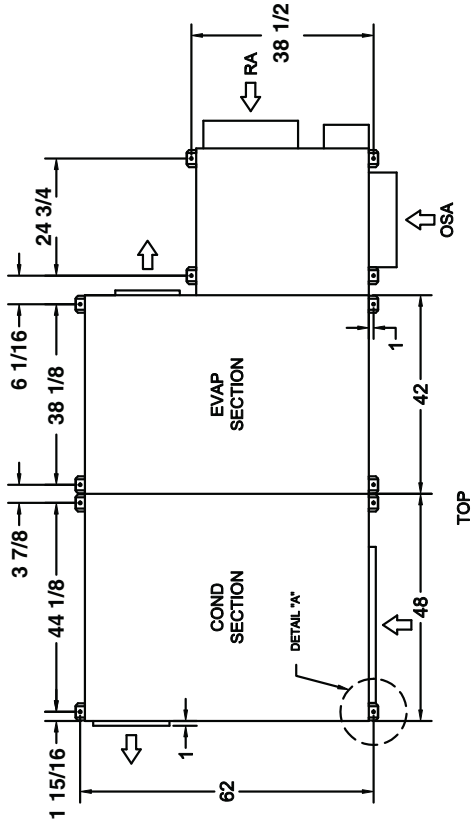

LEGEND
 OSA — Outside Supply Air
 RA — Return Air

NOTES:
 1. Dimensions are in inches.
 2. Economizer weight is 180 lb.

Fig. 3 — Unit Dimensions — 50AH024-060 Units with Factory-Installed Air-Side Economizer

OPERATING WEIGHT DISTRIBUTION

UNIT	WEIGHT OF CORNER (lb)							
	A	B	C	D	E	F	G	H
50AH								
072	125	128	149	152	126	128	188	192
096	126	129	149	153	139	142	208	212

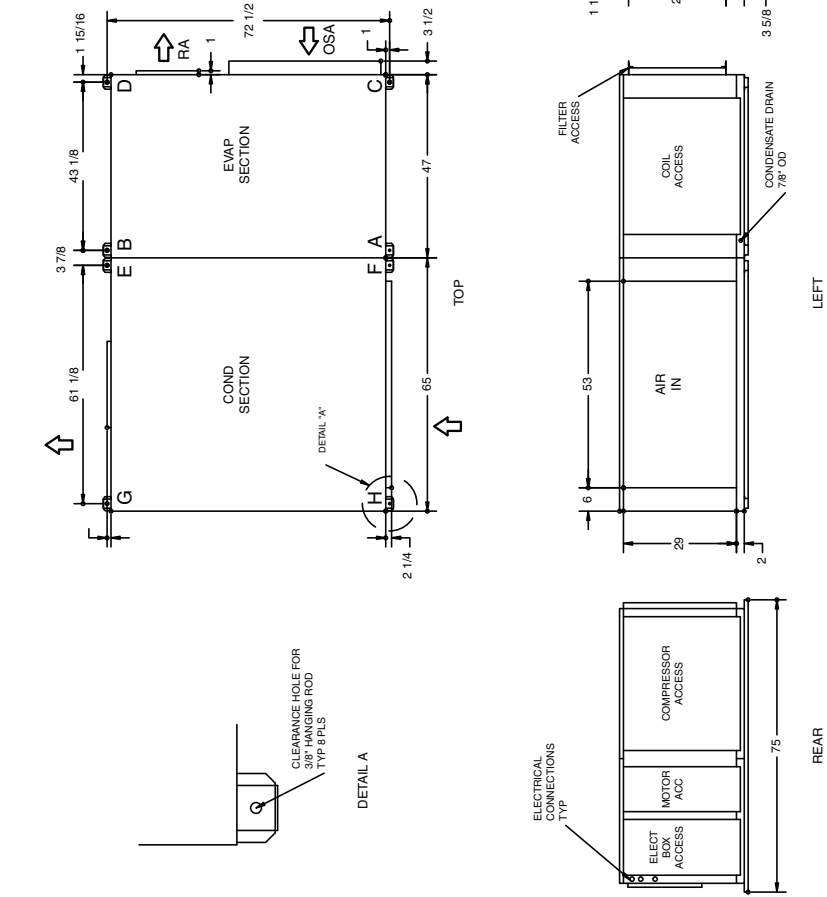

NOTE: Dimensions are in inches.

LEGEND

OSA — Outside Supply Air

RA — Return Air

Fig. 4 — Unit Dimensions — 50AH072,096 Standard Units

CENTER OF GRAVITY

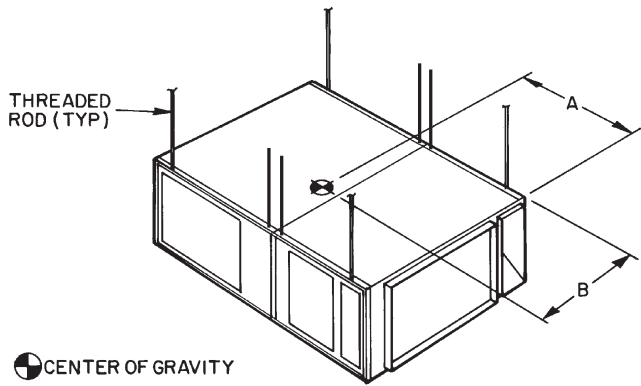

UNIT 50AH	DIMENSIONS (in.)	
	A	B
024	29.0	25.6
036	28.8	26.0
048	29.0	27.0
060	28.8	26.8
072	59.3	31.2
096	60.0	31.5

NOTE: Fasten threaded rods through holes in end frames as shown. Use 4 rods on each side of unit for a total of 8.

⚠ CAUTION

All panels must be in place when rigging.

CENTER OF GRAVITY

Fig. 6 — Rigging Details

Table 1 — Physical Data

UNIT 50AH	024	036	048
OPERATING WEIGHT (lb)			
Base Unit	903	910	952
Evaporator/Condenser Sections	399/484	401/489	417/515
SHIPPING WEIGHT (lb)*	1036	1043	1085
REFRIGERANT TYPE		R-410A	
Operating Charge (lb-oz)†	4-5	4-5	8-8
COMPRESSOR — TYPE		Scroll	
Quantity...Model	1...ZP20K5E	1...ZP31K5E	1...ZP38K5E
Oil (oz)	25	25	42
HPS Setting (psig)		650 ± 7	
Cutout		Manual Reset	
Reset			
LPS Setting (psig)		75 ± 7	
Cutout		100 ± 7	
Reset			
CONDENSATE DRAIN CONNECTION		7/8...OD	
Size (in.)...Type			
CONDENSER COIL		Copper Tubes — Aluminum Fins	
Size (L x H) (in.)	40 x 30	40 x 30	90 x 30
Number of Rows...Fins/in.	4...14	4...14	2...12
CONDENSER FAN		Centrifugal — Belt Drive	
Nominal Cfm	1700	2000	2500
Blower Size (in.)	15 x 15	15 x 15	15 x 15
Motor Hp (Rpm)			
Standard Motor	0.33 (1725)	0.33 (1725)	0.33 (1725)
Upgrade 1 Motor	—	—	0.50 (1725)
Upgrade 2 Motor	—	—	0.75 (1725)
EVAPORATOR COIL		Copper Tubes — Aluminum Fins	
Size (L x H) (in.)	32 x 16	32 x 16	32 x 26
Number of Rows...Fins/in.	3...12	3...12	3...14
EVAPORATOR AIR FAN		Centrifugal — Belt Drive	
Nominal Cfm	800	1200	1600
Blower Size (in.)	12 x 9	12 x 9	12 x 9
Motor Hp (Rpm)			
Standard Motor	0.25 (1725)	0.33 (1725)	0.33 (1725)
Upgrade 1 Motor	0.33 (1725)	0.50 (1725)	0.50 (1725)
Upgrade 2 Motor	0.50 (1725)	0.75 (1725)	0.75 (1725)
Upgrade 3 Motor	—	1.00 (1725)	1.00 (1725)
INDOOR-AIR FILTERS		Factory-Supplied Disposable Type	
Number...Size (in.)	2...18 x 24 x 1	2...18 x 24 x 1	2...18 x 24 x 1
INTERCONNECTING TUBING SIZE			
Suction (Qty...in.)	1...5/8	1...5/8	1...7/8
Liquid (Qty...in.)	1...3/8	1...3/8	1...3/8

LEGEND

HPS — High-Pressure Switch
LPS — Low-Pressure Switch

*Shipping weights include base unit plus packaging.
†If components are to be split, additional refrigerant will be needed.

NOTE: If components are to be split, the maximum length of refrigerant tubing to be used is 50 equivalent ft, assuming components will be installed in same horizontal plane. If components are not to be installed in same horizontal plane, contact your Carrier representative for more information. For additional piping information, refer to Carrier System Design Manual, Part 3.

Table 1 — Physical Data (cont)

UNIT 50AH	060	072	096
OPERATING WEIGHT (lb)			
Base Unit	960	1214	1283
Evaporator/Condenser Sections	421/519	554/634	556/701
SHIPPING WEIGHT (lb)*	1093	1647	1716
REFRIGERANT TYPE		R-410A	
Operating Charge (lb-oz)†	8-8	6-6	6-6
COMPRESSOR — TYPE		Scroll	
Quantity...Model	1...ZPKP51K5E	2...ZP31K5E	2...ZP38K5E
Oil (oz)	42	25	42
HPS Setting (psig)		650 ± 7	
Cutout		Manual Reset	
Reset			
LPS Setting (psig)		75 ± 7	
Cutout		100 ± 7	
Reset			
CONDENSATE DRAIN CONNECTION		7/8...OD	
Size (in.)...Type			
CONDENSER COIL		Copper Tubes — Aluminum Fins	
Size (L x H) (in.)	90 x 30	40 x 30 (2 coils)	40 x 30 (2 coils)
Number of Rows...Fins/in.	2...12	2...20	2...20
CONDENSER FAN		Centrifugal — Belt Drive	
Nominal Cfm	3000	5200	6400
Blower Size (in.)	15 x 15	18 x 18	18 x 18
Motor Hp (Rpm)			
Standard Motor	0.33 (1725)	1.00 (1725)	1.50 (1725)
Upgrade 1 Motor	0.50 (1725)	1.50 (1725)	2.00 (1725)
Upgrade 2 Motor	0.75 (1725)	—	3.00 (1725)
EVAPORATOR COIL		Copper Tubes — Aluminum Fins	
Size (L x H) (in.)	32 x 26	46 x 28	46 x 28
Number of Rows...Fins/in.	3...14	3...14	3...14
EVAPORATOR AIR FAN		Centrifugal — Belt Drive	
Nominal Cfm	2000	2400	3200
Blower Size (in.)	12 x 9	15 x 15	15 x 15
Motor Hp (Rpm)			
Standard Motor	0.33 (1725)	0.50 (1725)	0.75 (1725)
Upgrade 1 Motor	0.50 (1725)	0.75 (1725)	1.00 (1725)
Upgrade 2 Motor	0.75 (1725)	1.00 (1725)	1.50 (1725)
Upgrade 3 Motor	1.00 (1725)	1.50 (1725)	2.00 (1725)
INDOOR-AIR FILTERS		Factory-Supplied Disposable Type	
Number...Size (in.)	2...18 x 24 x 1	2...20 x 25 x 1	2...20 x 25 x 1
INTERCONNECTING TUBING SIZE			
Suction (Qty...in.)	1...7/8	1...5/8	1...7/8
Liquid (Qty...in.)	1...3/8	1...3/8	1...7/8

LEGEND

HPS — High-Pressure Switch
LPS — Low-Pressure Switch

*Shipping weights include base unit plus packaging.
†If components are to be split, additional refrigerant will be needed.

NOTE: If components are to be split, the maximum length of refrigerant tubing to be used is 50 equivalent ft, assuming components will be installed in same horizontal plane. If components are not to be installed in same horizontal plane, contact your Carrier representative for more information. For additional piping information, refer to Carrier System Design Manual, Part 3.

Step 4 — Rig and Place Unit — Move and store unit in horizontal position. Provide space around unit for service, filter access, ductwork, and overhead clearance as indicated in Fig. 2-5.

Using suitable hydraulic lift source, raise unit up to meet bottom of the 8 threaded rods suspended from ceiling (12 rods for units with air-side economizer). Center unit so that the 8 or 12 threaded rods can be easily inserted into the factory-drilled holes at each end. Refer to Fig. 6 for rigging details.

Apply washers and locknuts on ends of each of the 8 or 12 rods.

Tighten locknuts sufficiently so that unit weight is supported entirely by the 8 or 12 rods. Level unit within the space by adjusting locknuts.

IMPORTANT: Unit must be level to operate properly.

NOTE: For split systems, 8 (or 12) suspension rods are required (4 for each section and 4 for economizer if required). Refer to Splitting Systems section below.

Step 5 — Make Condensate Piping Connections — One 7/8-in. OD pipe thread condensate drain connection is provided for the evaporator section.

Step 6 — Install Ductwork — Use flexible ductwork to attach duct to unit and to help control transmission of vibrations to building structures. Attach ductwork to the return and supply ends of both coils.

If unit is located with condenser close to outside of building, install a field-supplied rainhood. Hood intake dimensions should be same as condenser return-air dimensions. In addition, install a triple-layer bird screen over rainhood intake to eliminate possibility of insects, birds, water, or debris from entering unit. Ensure hood and/or louvers are installed correctly to avoid condenser air recirculation.

Step 7 — Split Systems (Factory Option, if Required) — The Roomtop® 50AH units may be split into 2 sections, if desired, with condensing section mounted remotely horizontally. The unit must be ordered with the “Splittable” cabinet type as shown in the unit model number nomenclature. See Fig. 1. All splittable units come with the interconnecting tubing kit.

Sections installed in the same horizontal plane may be separated by up to 50 equivalent ft of tubing. Use type L copper or better.

Condensing section must be located in same plane as, or above, evaporator section to maintain the liquid refrigerant seal at the expansion device. This permits expansion device to feed liquid refrigerant to evaporator coil properly. To split sections (some of the following steps may be eliminated depending on particular application):

1. Disconnect all electrical power to unit.
2. Remove the 10 size 10 drive screws that hold on the top tie strap.
3. Remove the 8 size $\frac{3}{8}$ -in. drive bolts that hold on each side angle.
4. Control panel access panels are held on with 2 size 10 drive screws for each panel. A standard 50AH024-060 unit has one control panel located in the evaporator section. A standard 50AH072 or 096 unit has a control panel in both the evaporator and condenser sections.
5. Units have resealable fittings. Do not cut refrigerant piping. See Interconnecting Refrigerant Tubing section below for procedure on installing tubing.
6. Install evaporator and condensing sections in desired locations.
7. Use sufficient length of refrigerant piping to reconnect piping cut in previous step. Refer to Carrier System Design Manual, Part 3, for additional piping data.
8. Recharge unit with R-410A. See Refrigerant Charge section on page 18 for more information.

After splitting sections, additional refrigerant must be added to system to ensure proper refrigerant charge. The amount of refrigerant to be added depends on length of tubing added to system and operating temperatures of system. Refer to Carrier System Design Manual, Chapter 3. Allow unit to operate at least 10 minutes before adjusting refrigerant charge.

Since standard roomtop unit has negligible line losses, splitting the system can increase line loss and decrease system capacity. Capacity reduction can be determined by referring to Carrier System Design Manual.

INTERCONNECTING REFRIGERANT TUBING — The interconnecting tubing kit comes with all factory-optional splitable units. After the separated sections have been installed, the interconnecting tubing can be run, using the self-sealing couplings supplied in the interconnect tubing kit (see Fig. 7 and 8).

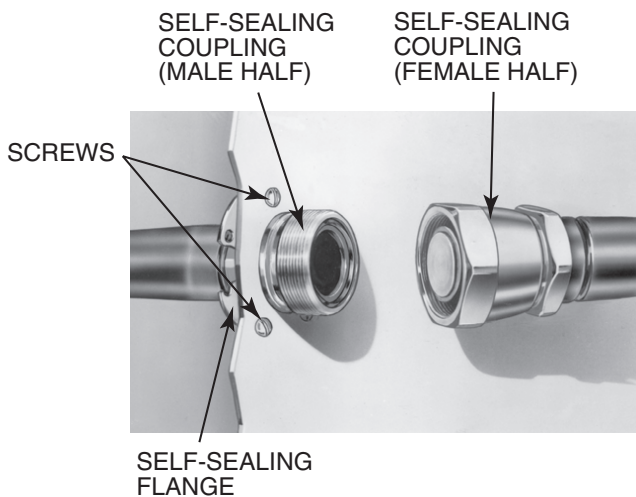

Fig. 7 — Self Sealing Coupling

For dual circuits, 2 kits are supplied. It is recommended that some refrigerant oil be placed on the coupling threads to facilitate threading.

Perform the following procedure:

1. For condensing section, hand thread the female halves of the self-sealing couplings (supplied with the interconnect tubing kit) onto the male couplings (factory supplied and installed on the condensing section). Turn union nut approximately 1 to $1\frac{1}{2}$ turns. This is to make sure that the interconnecting tubing will be routed and brazed with the self-sealing couplings in their final proper location, so that there will be no difficulty when the final coupling assembly is made.
2. For evaporator section, hand thread the male halves of the self-sealing couplings (supplied with the interconnect tubing kit) onto the female couplings (factory supplied and installed on the evaporating section). Turn union nut approximately 1 to $1\frac{1}{2}$ turns. This is to make sure that the interconnecting tubing will be routed and brazed with the self-sealing couplings in their final proper location, so that there will be no difficulty when the final coupling assembly is made.
3. Run the interconnecting tubing required.

NOTE: Installations may be made with up to 50 ft equivalent line lengths by installing the recommended tube sizes and adding the necessary refrigerant. For equivalent line lengths greater than 50 ft, contact Carrier for line sizing and additional accessories required.

IMPORTANT: On units with more than one refrigerant circuit, be careful not to intermix lines of the various circuits. If the connections were labeled before disconnecting the couplings, this should not be a problem. Half couplings may be removed to make brazing to the interconnecting tubing more convenient.

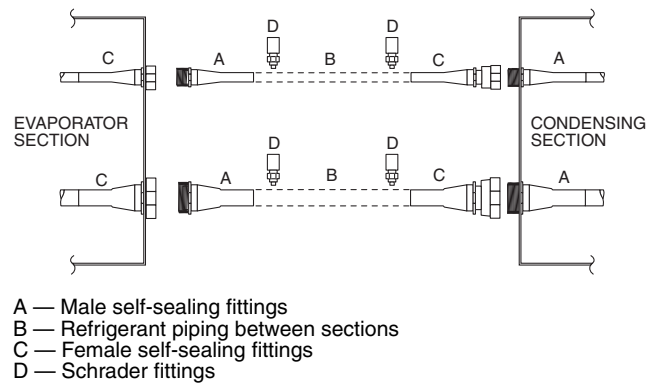

Fig. 8 — Tubing Installation

CAUTION

When brazing tubing to the self-sealing couplings, be sure to use a wet rag, running water bath or chill blocks on the quick-connects to prevent overheating the valves and damaging the seals.

4. The interconnect tubing kit contains a sufficient number of Schrader access valves to permit installation of one in each end of both the liquid and suction lines of the field-supplied tubing. Each interconnecting line (suction, liquid, hot gas) must have one of the supplied Schrader access fittings installed into the field-supplied tubing, however, for short lengths of tubing, only one Schrader in each line is necessary. Install the Schrader valve fittings into the tubing before brazing the couplings onto the ends

of the tubing. Use a 1/4-in. hole to mount the valve. Clean and debur the tubing before doing any brazing to ensure that no chips or debris are left in the refrigerant circuit. Remove the Schrader valve cap and core before doing any brazing.

5. After brazing the tubing to the self-sealing coupling halves, evacuate each line to 500 microns. Check to make sure that each line holds a vacuum after removal of the vacuum pump (indicating no leaks). Add the appropriate charge of R-410A refrigerant using the Schrader valves. Refasten male halves to outer back panel of evaporator section with flanges and screws (if they were removed for brazing to tubing). Wipe off coupling seals and threaded surfaces with a clean cloth to prevent the inclusion of dirt or foreign material into the system. Lubricate rubber seal and metal seal in the male halves with refrigeration oil. Thread coupling halves together by hand to ensure proper mating of threads. Continue to handthread each half-coupling to its mating half until resistance is felt (approximately 1 1/2 to 1 3/4 turns). Complete the connection of the mating half-couplings with a wrench. The suction line couplings (size 12) will be totally engaged after an additional 5 1/2 to 5 3/4 turns. The liquid line couplings (size 8) will be totally engaged after an additional 4 1/2 to 4 3/4 turns. Use a backup wrench to prevent the couplings from twisting.
6. Refrigerant piping must be insulated in accordance with local codes and/or applicable ASHRAE standards. Insulation exposed to weather must be suitable for outdoor use. Provide protection from water and shielding from solar radiation as necessary.
7. Add refrigerant to the system to compensate for the additional interconnecting tubing. The suction line should be pitched downward to the compressor, sloping approximately 1/4-in. every 10 ft to facilitate oil return. P-traps (field supplied) are required for all suction line risers every 15 ft. When the evaporator is above the condensing section, an inverted P-trap should be incorporated as close as possible to the evaporator (this minimizes flood-back/oil slugging during the off cycle). If the condensing

section is more than 50 ft above the evaporator, consult Carrier for specific refrigeration components.

Step 8 — Make Electrical Connections — Connect power wiring to junction box located on unit side near control box access panel. All wiring must comply with National Electrical Code (NEC) and all local code requirements.

Operating voltage to compressor must be within voltage range as indicated on unit nameplate. On 3-phase units, voltages between phases must be balanced within 2% and current must be balanced within 10%. Contact local power company for correction of improper voltage or phase imbalance. Unit failure as a result of operation on improper line voltage or excessive phase imbalance constitutes abuse and may cause damage to electrical components. Such operation would invalidate any applicable Carrier warranty.

Install a fused disconnect per NEC. Refer to unit nameplate and Tables 2A-2L for fuse sizes and wire amperages for all units.

FIELD CONTROL WIRING — Install a Carrier-approved accessory thermostat assembly according to installation instructions provided by thermostat manufacturer. Locate thermostat assembly on a solid wall in the conditioned space away from drafts to sense average room temperature.

Using thermostat cable or equivalent single leads of no. 18 AWG (American Wire Gage) colored wire, route cable or wire from the subbase terminals, up and through connector on unit side (below power lead junction box) and connect to low-voltage terminal block inside the control box.

THERMOSTAT WIRE — Use 18 gage for 0 to 50-ft long wires and 16 gage for 51 to 75-ft wire lengths.

Step 9 — Adjust Fan Speed — Adjust fan speed to meet jobsite conditions. Refer to Tables 3 and 4 to determine fan speed settings. See Service section of this document for instructions to adjust fan speed.

The evaporator and condenser fan motors on all units are belt drive.

Table 2A — Electrical Data — Standard Evaporator Motor with Standard Condenser Motor

UNIT 50AH	V-PH (60 Hz)	VOLTAGE RANGE		COMPRESSOR			FAN MOTORS				POWER SUPPLY	
		Min	Max	QTY	RLA	LRA	Evaporator (Standard)		Condenser (Standard)		Min Ckt Amps	MOCP Amps
							Hp	FLA	Hp	FLA		
024	208/230-1	187	254	1	13.5	58.0	1/4	1.25	1/3	1.7	19.8	35
036	208/230-1	187	254	1	16.7	79.0	1/3	1.7	1/3	1.7	24.3	40
	208/230-3	187	254		10.4	73.0	1/3	1.3	1/3	1.3	15.6	25
	460-3	414	508		5.8	38.0	1/3	0.7	1/3	0.7	8.6	15
048	208/230-1	187	254	1	19.9	109.0	1/3	1.7	1/3	1.7	28.3	50
	208/230-3	187	254		13.6	83.1	1/3	1.3	1/3	1.3	19.6	35
	460-3	414	508		6.1	41.0	1/3	0.7	1/3	0.7	8.9	15
060	208/230-1	187	254	1	26.4	134	1/3	1.7	1/3	1.7	36.4	65
	208/230-3	187	254		16.0	110.0	1/3	1.3	1/3	1.3	22.6	40
	460-3	414	508		7.8	52.0	1/3	0.7	1/3	0.7	11.1	20
072*	208/230-1	187	254	2	16.7	79.0	1/2	2.5	1	4.2	44.3	60
	208/230-3	187	254		10.4	73.0	1/2	1.8	1	3.2	28.4	40
	460-3	414	508		5.8	38.0	1/2	0.9	1	1.6	15.6	20
096*	208/230-1	187	254	2	19.9	109.0	3/4	3.2	1 1/2	6.5	54.5	75
	208/230-3	187	254		13.6	83.1	3/4	2.4	1 1/2	4.8	37.8	50
	460-3	414	508		6.1	41.0	3/4	1.2	1 1/2	2.4	17.3	25

LEGEND

- HACR — Heating, Air Conditioning, and Refrigeration
- Hp — Horsepower
- FLA — Full Load Amps
- LRA — Locked Rotor Amps
- MOCP — Maximum Overcurrent Protection (HACR breaker)
- RLA — Rated Load Amps

*Unit has two compressors.



Table 2B — Electrical Data — Upgrade 1 Evaporator Motor with Standard Condenser Motor

UNIT 50AH	V-PH (60 Hz)	VOLTAGE RANGE		COMPRESSOR			FAN MOTORS				POWER SUPPLY	
							Evaporator (Upgrade 1)		Condenser (Standard)			
		Min	Max	QTY	RLA	LRA	Hp	FLA	Hp	FLA	Min Ckt Amps	MOCP Amps
024	208/230-1	187	254	1	13.5	58.0	1/3	1.7	1/3	1.7	20.3	35
036	208/230-1	187	254	1	16.7	79.0	1/2	2.5	1/3	1.7	25.1	40
	208/230-3	187	254		10.4	73.0	1/2	1.8	1/3	1.3	16.1	25
	460-3	414	508		5.8	38.0	1/2	0.9	1/3	0.7	8.8	15
048	208/230-1	187	254	1	19.9	109.0	1/2	2.5	1/3	1.7	29.1	50
	208/230-3	187	254		13.6	83.1	1/2	1.8	1/3	1.3	20.1	35
	460-3	414	508		6.1	41.0	1/2	0.9	1/3	0.7	9.2	15
060	208/230-1	187	254	1	26.4	134.0	1/2	2.5	1/3	1.7	37.2	65
	208/230-3	187	254		16.0	110.0	1/2	1.8	1/3	1.3	23.1	40
	460-3	414	508		7.8	52.0	1/2	0.9	1/3	0.7	11.3	20
072*	208/230-1	187	254	2	16.7	79.0	3/4	3.2	1	4.2	45.0	60
	208/230-3	187	254		10.4	73.0	3/4	2.4	1	3.2	29.0	40
	460-3	414	508		5.8	38.0	3/4	1.2	1	1.6	15.9	20
096*	208/230-1	187	254	2	19.9	109.0	1	4.2	1 1/2	6.5	55.5	75
	208/230-3	187	254		13.6	83.1	1	3.2	1 1/2	4.8	38.6	50
	460-3	414	508		6.1	41.0	1	1.6	1 1/2	2.4	17.7	25

Table 2C — Electrical Data — Upgrade 2 Evaporator Motor with Standard Condenser Motor

UNIT 50AH	V-PH (60 Hz)	VOLTAGE RANGE		COMPRESSOR			FAN MOTORS				POWER SUPPLY	
							Evaporator (Upgrade 2)		Condenser (Standard)			
		Min	Max	QTY	RLA	LRA	Hp	FLA	Hp	FLA	Min Ckt Amps	MOCP Amps
024	208/230-1	187	254	1	13.5	58.0	1/2	2.5	1/3	1.7	21.1	35
036	208/230-1	187	254	1	16.7	79.0	3/4	3.2	1/3	1.7	25.8	40
	208/230-3	187	254		10.4	73.0	3/4	2.4	1/3	1.3	16.7	25
	460-3	414	508		5.8	38.0	3/4	1.2	1/3	0.7	9.1	15
048	208/230-1	187	254	1	19.9	109.0	3/4	3.2	1/3	1.7	29.8	50
	208/230-3	187	254		13.6	83.1	3/4	2.4	1/3	1.3	20.7	35
	460-3	414	508		6.1	41.0	3/4	1.2	1/3	0.7	9.5	15
060	208/230-1	187	254	1	26.4	134.0	3/4	3.2	1/3	1.7	37.9	65
	208/230-3	187	254		16.0	110.0	3/4	2.4	1/3	1.3	23.7	40
	460-3	414	508		7.8	52.0	3/4	1.2	1/3	0.7	11.6	20
072*	208/230-1	187	254	2	16.7	79.0	1	4.2	1	4.2	46.0	60
	208/230-3	187	254		10.4	73.0	1	3.2	1	3.2	29.8	40
	460-3	414	508		5.8	38.0	1	1.6	1	1.6	16.3	20
096*	208/230-1	187	254	2	19.9	109.0	1 1/2	6.5	1 1/2	6.5	57.8	80
	208/230-3	187	254		13.6	83.1	1 1/2	4.8	1 1/2	4.8	40.2	55
	460-3	414	508		6.1	41.0	1 1/2	2.4	1 1/2	2.4	18.5	25

LEGEND

- HACR — Heating, Air Conditioning, and Refrigeration
- Hp — Horsepower
- FLA — Full Load Amps
- LRA — Locked Rotor Amps
- MOCP — Maximum Overcurrent Protection (HACR breaker)
- RLA — Rated Load Amps

*Unit has two compressors.



Table 2D — Electrical Data — Upgrade 3 Evaporator Motor with Standard Condenser Motor

UNIT 50AH	V-PH (60 Hz)	VOLTAGE RANGE		COMPRESSOR			FAN MOTORS				POWER SUPPLY	
		Min	Max	QTY	RLA	LRA	Evaporator (Upgrade 3)		Condenser (Standard)		Min Ckt Amps	MOCP Amps
							Hp	FLA	Hp	FLA		
024	208/230-1	187	254	1	N/A	N/A	N/A	N/A	N/A	N/A	N/A	N/A
036	208/230-1	187	254	1	16.7	79.0	1	3.2	1/3	1.7	25.8	40
	208/230-3	187	254		10.4	73.0	1	2.4	1/3	1.3	16.7	25
	460-3	414	508		5.8	38.0	1	1.2	1/3	0.7	9.1	15
048	208/230-1	187	254	1	19.9	109.0	1	3.2	1/3	1.7	29.8	50
	208/230-3	187	254		13.6	83.1	1	2.4	1/3	1.3	20.7	35
	460-3	414	508		6.1	41.0	1	1.2	1/3	0.7	9.5	15
060	208/230-1	187	254	1	26.4	134.0	1	3.2	1/3	1.7	37.9	65
	208/230-3	187	254		16.0	110.0	1	2.4	1/3	1.3	23.7	40
	460-3	414	508		7.8	52.0	1	1.2	1/3	0.7	11.6	20
072*	208/230-1	187	254	2	16.7	79.0	1 1/2	6.5	1	4.2	48.3	65
	208/230-3	187	254		10.4	73.0	1 1/2	4.8	1	3.2	31.4	40
	460-3	414	508		5.8	38.0	1 1/2	2.4	1	1.6	17.1	25
096*	208/230-1	187	254	2	N/A	N/A	N/A	N/A	N/A	N/A	N/A	N/A
	208/230-3	187	254		13.6	83.1	2	6.0	1 1/2	4.8	41.4	55
	460-3	414	508		6.1	41.0	2	2.9	1 1/2	2.4	19.0	25

Table 2E — Electrical Data — Standard Evaporator Motor with Upgrade 1 Condenser Motor

UNIT 50AH	V-PH (60 Hz)	VOLTAGE RANGE		COMPRESSOR			FAN MOTORS				POWER SUPPLY	
		Min	Max	QTY	RLA	LRA	Evaporator (Standard)		Condenser (Upgrade 1)		Min Ckt Amps	MOCP Amps
							Hp	FLA	Hp	FLA		
024	208/230-1	187	254	1	N/A	N/A	N/A	N/A	N/A	N/A	N/A	N/A
036	208/230-1	187	254	1	N/A	N/A	N/A	N/A	N/A	N/A	N/A	N/A
	208/230-3	187	254		N/A	N/A	N/A	N/A	N/A	N/A	N/A	N/A
	460-3	414	508		N/A	N/A	N/A	N/A	N/A	N/A	N/A	N/A
048	208/230-1	187	254	1	19.9	109.0	1/3	1.7	1/2	2.5	29.1	50
	208/230-3	187	254		13.6	83.1	1/3	1.3	1/2	1.8	20.1	35
	460-3	414	508		6.1	41.0	1/3	0.7	1/2	0.9	9.2	15
060	208/230-1	187	254	1	26.4	134.0	1/3	1.7	1/2	2.5	37.2	65
	208/230-3	187	254		16.0	110.0	1/3	1.3	1/2	1.8	23.1	40
	460-3	414	508		7.8	52.0	1/3	0.7	1/2	0.9	11.3	20
072*	208/230-1	187	254	2	16.7	79.0	1/2	2.5	1 1/2	6.5	46.6	65
	208/230-3	187	254		10.4	73.0	1/2	1.8	1 1/2	4.8	30.0	40
	460-3	414	508		5.8	38.0	1/2	0.9	1 1/2	2.4	16.4	20
096*	208/230-1	187	254	2	N/A	N/A	N/A	N/A	N/A	N/A	N/A	N/A
	208/230-3	187	254		13.6	83.1	3/4	2.4	2	6.0	39.0	55
	460-3	414	508		6.1	41.0	3/4	1.2	2	2.9	17.8	25

LEGEND

- HACR** — Heating, Air Conditioning, and Refrigeration
- Hp** — Horsepower
- FLA** — Full Load Amps
- LRA** — Locked Rotor Amps
- MOCP** — Maximum Overcurrent Protection (HACR breaker)
- RLA** — Rated Load Amps

*Unit has two compressors.



Table 2F — Electrical Data — Upgrade 1 Evaporator Motor with Upgrade 1 Condenser Motor

UNIT 50AH	V-PH (60 Hz)	VOLTAGE RANGE		COMPRESSOR			FAN MOTORS				POWER SUPPLY	
		Min	Max	QTY	RLA	LRA	Evaporator (Upgrade 1)		Condenser (Upgrade 1)		Min Ckt Amps	MOCP Amps
							Hp	FLA	Hp	FLA		
024	208/230-1	187	254	1	N/A	N/A	N/A	N/A	N/A	N/A	N/A	N/A
036	208/230-1	187	254	1	N/A	N/A	N/A	N/A	N/A	N/A	N/A	N/A
	208/230-3	187	254		N/A	N/A	N/A	N/A	N/A	N/A	N/A	N/A
	460-3	414	508		N/A	N/A	N/A	N/A	N/A	N/A	N/A	N/A
048	208/230-1	187	254	1	19.9	109.0	1/2	2.5	1/2	2.5	29.9	50
	208/230-3	187	254		13.6	83.1	1/2	1.8	1/2	1.8	20.6	35
	460-3	414	508		6.1	41.0	1/2	0.9	1/2	0.9	9.4	15
060	208/230-1	187	254	1	26.4	134.0	1/2	2.5	1/2	2.5	38.0	65
	208/230-3	187	254		16.0	110.0	1/2	1.8	1/2	1.8	23.6	40
	460-3	414	508		7.8	52.0	1/2	0.9	1/2	0.9	11.6	20
072*	208/230-1	187	254	2	16.7	79.0	3/4	3.2	1 1/2	6.5	47.3	65
	208/230-3	187	254		10.4	73.0	3/4	2.4	1 1/2	4.8	30.6	40
	460-3	414	508		5.8	38.0	3/4	1.2	1 1/2	2.4	16.7	20
096*	208/230-1	187	254	2	N/A	N/A	N/A	N/A	N/A	N/A	N/A	N/A
	208/230-3	187	254		13.6	83.1	1	3.2	2	6.0	39.8	55
	460-3	414	508		6.1	41.0	1	1.6	2	2.9	18.2	25

Table 2G — Electrical Data — Upgrade 2 Evaporator Motor with Upgrade 1 Condenser Motor

UNIT 50AH	V-PH (60 Hz)	VOLTAGE RANGE		COMPRESSOR			FAN MOTORS				POWER SUPPLY	
		Min	Max	QTY	RLA	LRA	Evaporator (Upgrade 2)		Condenser (Upgrade 1)		Min Ckt Amps	MOCP Amps
							Hp	FLA	Hp	FLA		
024	208/230-1	187	254	1	N/A	N/A	N/A	N/A	N/A	N/A	N/A	N/A
036	208/230-1	187	254	1	N/A	N/A	N/A	N/A	N/A	N/A	N/A	N/A
	208/230-3	187	254		N/A	N/A	N/A	N/A	N/A	N/A	N/A	N/A
	460-3	414	508		N/A	N/A	N/A	N/A	N/A	N/A	N/A	N/A
048	208/230-1	187	254	1	19.9	109.0	3/4	3.2	1/2	2.5	30.6	50
	208/230-3	187	254		13.6	83.1	3/4	2.4	1/2	1.8	21.2	35
	460-3	414	508		6.1	41.0	3/4	1.2	1/2	0.9	9.7	15
060	208/230-1	187	254	1	26.4	134.0	3/4	3.2	1/2	2.5	38.7	65
	208/230-3	187	254		16.0	110.0	3/4	2.4	1/2	1.8	24.2	40
	460-3	414	508		7.8	52.0	3/4	1.2	1/2	0.9	11.9	20
072*	208/230-1	187	254	2	16.7	79.0	1	4.2	1 1/2	6.5	48.3	65
	208/230-3	187	254		10.4	73.0	1	3.2	1 1/2	4.8	31.4	40
	460-3	414	508		5.8	38.0	1	1.6	1 1/2	2.4	17.1	25
096*	208/230-1	187	254	2	N/A	N/A	N/A	N/A	N/A	N/A	N/A	N/A
	208/230-3	187	254		13.6	83.1	1 1/2	4.8	2	6.0	41.4	55
	460-3	414	508		6.1	41.0	1 1/2	2.4	2	2.9	19.0	25

LEGEND

- HACR** — Heating, Air Conditioning, and Refrigeration
- Hp** — Horsepower
- FLA** — Full Load Amps
- LRA** — Locked Rotor Amps
- MOCP** — Maximum Overcurrent Protection (HACR breaker)
- RLA** — Rated Load Amps

*Unit has two compressors.



Table 2H — Electrical Data — Upgrade 3 Evaporator Motor with Upgrade 1 Condenser Motor

UNIT 50AH	V-PH (60 Hz)	VOLTAGE RANGE		COMPRESSOR			FAN MOTORS				POWER SUPPLY	
		Min	Max	QTY	RLA	LRA	Evaporator (Upgrade 3)		Condenser (Upgrade 1)		Min Ckt Amps	MOCP Amps
							Hp	FLA	Hp	FLA		
024	208/230-1	187	254	1	N/A	N/A	N/A	N/A	N/A	N/A	N/A	N/A
036	208/230-1	187	254	1	N/A	N/A	N/A	N/A	N/A	N/A	N/A	N/A
	208/230-3	187	254		N/A	N/A	N/A	N/A	N/A	N/A	N/A	N/A
	460-3	414	508		N/A	N/A	N/A	N/A	N/A	N/A	N/A	N/A
048	208/230-1	187	254	1	19.9	109.0	1	3.2	1/2	2.5	30.6	50
	208/230-3	187	254		13.6	83.1	1	2.4	1/2	1.8	21.2	35
	460-3	414	508		6.1	41.0	1	1.2	1/2	0.9	9.7	15
060	208/230-1	187	254	1	26.4	134.0	1	3.2	1/2	2.5	38.7	65
	208/230-3	187	254		16.0	110.0	1	2.4	1/2	1.8	24.2	40
	460-3	414	508		7.8	52.0	1	1.2	1/2	0.9	11.9	20
072*	208/230-1	187	254	2	16.7	79.0	1 1/2	6.5	1 1/2	6.5	50.6	65
	208/230-3	187	254		10.4	73.0	1 1/2	4.8	1 1/2	4.8	33.0	45
	460-3	414	508		5.8	38.0	1 1/2	2.4	1 1/2	2.4	17.9	25
096*	208/230-1	187	254	2	N/A	N/A	N/A	N/A	N/A	N/A	N/A	N/A
	208/230-3	187	254		13.6	83.1	2	6.0	2	6.0	42.6	55
	460-3	414	508		6.1	41.0	2	2.9	2	2.9	19.5	25

Table 2I — Electrical Data — Standard Evaporator Motor with Upgrade 2 Condenser Motor

UNIT 50AH	V-PH (60 Hz)	VOLTAGE RANGE		COMPRESSOR			FAN MOTORS				POWER SUPPLY	
		Min	Max	QTY	RLA	LRA	Evaporator (Standard)		Condenser (Upgrade 2)		Min Ckt Amps	MOCP Amps
							Hp	FLA	Hp	FLA		
024	208/230-1	187	254	1	N/A	N/A	N/A	N/A	N/A	N/A	N/A	N/A
036	208/230-1	187	254	1	N/A	N/A	N/A	N/A	N/A	N/A	N/A	N/A
	208/230-3	187	254		N/A	N/A	N/A	N/A	N/A	N/A	N/A	N/A
	460-3	414	508		N/A	N/A	N/A	N/A	N/A	N/A	N/A	N/A
048	208/230-1	187	254	1	19.9	109.0	1/3	1.7	3/4	3.2	29.8	50
	208/230-3	187	254		13.6	83.1	1/3	1.3	3/4	2.4	20.7	35
	460-3	414	508		6.1	41.0	1/3	0.7	3/4	1.2	9.5	15
060	208/230-1	187	254	1	26.4	134.0	1/3	1.7	3/4	3.2	37.9	65
	208/230-3	187	254		16.0	110.0	1/3	1.3	3/4	2.4	23.7	40
	460-3	414	508		7.8	52.0	1/3	0.7	3/4	1.2	11.6	20
072*	208/230-1	187	254	2	N/A	N/A	N/A	N/A	N/A	N/A	N/A	N/A
	208/230-3	187	254		N/A	N/A	N/A	N/A	N/A	N/A	N/A	N/A
	460-3	414	508		N/A	N/A	N/A	N/A	N/A	N/A	N/A	N/A
096*	208/230-1	187	254	2	N/A	N/A	N/A	N/A	N/A	N/A	N/A	N/A
	208/230-3	187	254		13.6	83.1	3/4	2.4	3	8.4	41.4	55
	460-3	414	508		6.1	41.0	3/4	1.2	3	4.0	18.9	25

LEGEND

- HACR** — Heating, Air Conditioning, and Refrigeration
- Hp** — Horsepower
- FLA** — Full Load Amps
- LRA** — Locked Rotor Amps
- MOCP** — Maximum Overcurrent Protection (HACR breaker)
- RLA** — Rated Load Amps

*Unit has two compressors.



Table 2J — Electrical Data — Upgrade 1 Evaporator Motor with Upgrade 2 Condenser Motor

UNIT 50AH	V-PH (60 Hz)	VOLTAGE RANGE		COMPRESSOR			FAN MOTORS				POWER SUPPLY	
		Min	Max	QTY	RLA	LRA	Evaporator (Upgrade 1)		Condenser (Upgrade 2)		Min Ckt Amps	MOCP Amps
							Hp	FLA	Hp	FLA		
024	208/230-1	187	254	1	N/A	N/A	N/A	N/A	N/A	N/A	N/A	N/A
036	208/230-1	187	254	1	N/A	N/A	N/A	N/A	N/A	N/A	N/A	N/A
	208/230-3	187	254		N/A	N/A	N/A	N/A	N/A	N/A	N/A	N/A
	460-3	414	508		N/A	N/A	N/A	N/A	N/A	N/A	N/A	N/A
048	208/230-1	187	254	1	19.9	109.0	1/2	2.5	3/4	3.2	30.6	50
	208/230-3	187	254		13.6	83.1	1/2	1.8	3/4	2.4	21.2	35
	460-3	414	508		6.1	41.0	1/2	0.9	3/4	1.2	9.7	15
060	208/230-1	187	254	1	26.4	134.0	1/2	2.5	3/4	3.2	38.7	65
	208/230-3	187	254		16.0	110.0	1/2	1.8	3/4	2.4	24.2	40
	460-3	414	508		7.8	52.0	1/2	0.9	3/4	1.2	11.9	20
072*	208/230-1	187	254	2	N/A	N/A	N/A	N/A	N/A	N/A	N/A	N/A
	208/230-3	187	254		N/A	N/A	N/A	N/A	N/A	N/A	N/A	N/A
	460-3	414	508		N/A	N/A	N/A	N/A	N/A	N/A	N/A	N/A
096*	208/230-1	187	254	2	N/A	N/A	N/A	N/A	N/A	N/A	N/A	N/A
	208/230-3	187	254		13.6	83.1	1	3.2	3	8.4	42.2	55
	460-3	414	508		6.1	41.0	1	1.6	3	4.0	19.3	25

Table 2K — Electrical Data — Upgrade 2 Evaporator Motor with Upgrade 2 Condenser Motor

UNIT 50AH	V-PH (60 Hz)	VOLTAGE RANGE		COMPRESSOR			FAN MOTORS				POWER SUPPLY	
		Min	Max	QTY	RLA	LRA	Evaporator (Upgrade 2)		Condenser (Upgrade 2)		Min Ckt Amps	MOCP Amps
							Hp	FLA	Hp	FLA		
024	208/230-1	187	254	1	N/A	N/A	N/A	N/A	N/A	N/A	N/A	N/A
036	208/230-1	187	254	1	N/A	N/A	N/A	N/A	N/A	N/A	N/A	N/A
	208/230-3	187	254		N/A	N/A	N/A	N/A	N/A	N/A	N/A	N/A
	460-3	414	508		N/A	N/A	N/A	N/A	N/A	N/A	N/A	N/A
048	208/230-1	187	254	1	19.9	109.0	3/4	3.2	3/4	3.2	31.3	50
	208/230-3	187	254		13.6	83.1	3/4	2.4	3/4	2.4	21.8	35
	460-3	414	508		6.1	41.0	3/4	1.2	3/4	1.2	10.0	15
060	208/230-1	187	254	1	26.4	134.0	3/4	3.2	3/4	3.2	39.4	65
	208/230-3	187	254		16.0	110.0	3/4	2.4	3/4	2.4	24.8	40
	460-3	414	508		7.8	52.0	3/4	1.2	3/4	1.2	12.2	20
072*	208/230-1	187	254	2	N/A	N/A	N/A	N/A	N/A	N/A	N/A	N/A
	208/230-3	187	254		N/A	N/A	N/A	N/A	N/A	N/A	N/A	N/A
	460-3	414	508		N/A	N/A	N/A	N/A	N/A	N/A	N/A	N/A
096*	208/230-1	187	254	2	N/A	N/A	N/A	N/A	N/A	N/A	N/A	N/A
	208/230-3	187	254		13.6	83.1	1 1/2	4.8	3	8.4	43.8	55
	460-3	414	508		6.1	41.0	1 1/2	2.4	3	4.0	20.1	25

LEGEND

- HACR** — Heating, Air Conditioning, and Refrigeration
- Hp** — Horsepower
- FLA** — Full Load Amps
- LRA** — Locked Rotor Amps
- MOCP** — Maximum Overcurrent Protection (HACR breaker)
- RLA** — Rated Load Amps

*Unit has two compressors.



Table 2L — Electrical Data — Upgrade 3 Evaporator Motor with Upgrade 2 Condenser Motor

UNIT 50AH	V-PH (60 Hz)	VOLTAGE RANGE		COMPRESSOR			FAN MOTORS				POWER SUPPLY	
		Min	Max	QTY	RLA	LRA	Evaporator (Upgrade 3)		Condenser (Upgrade 2)		Min Ckt Amps	MOCP Amps
							Hp	FLA	Hp	FLA		
024	208/230-1	187	254	1	N/A	N/A	N/A	N/A	N/A	N/A	N/A	N/A
036	208/230-1	187	254	1	N/A	N/A	N/A	N/A	N/A	N/A	N/A	N/A
	208/230-3	187	254		N/A	N/A	N/A	N/A	N/A	N/A	N/A	N/A
	460-3	414	508		N/A	N/A	N/A	N/A	N/A	N/A	N/A	N/A
048	208/230-1	187	254	1	19.9	109.0	1	3.2	3/4	3.2	31.3	50
	208/230-3	187	254		13.6	83.1	1	2.4	3/4	2.4	21.8	35
	460-3	414	508		6.1	41.0	1	1.2	3/4	1.2	10.0	15
060	208/230-1	187	254	1	26.4	134.0	1	3.2	3/4	3.2	39.4	65
	208/230-3	187	254		16.0	110.0	1	2.4	3/4	2.4	24.8	40
	460-3	414	508		7.8	52.0	1	1.2	3/4	1.2	12.2	20
072*	208/230-1	187	254	2	N/A	N/A	N/A	N/A	N/A	N/A	N/A	N/A
	208/230-3	187	254		N/A	N/A	N/A	N/A	N/A	N/A	N/A	N/A
	460-3	414	508		N/A	N/A	N/A	N/A	N/A	N/A	N/A	N/A
096*	208/230-1	187	254	2	N/A	N/A	N/A	N/A	N/A	N/A	N/A	N/A
	208/230-3	187	254		13.6	83.1	2	6.0	3	8.4	45.0	55
	460-3	414	508		6.1	41.0	2	2.9	3	4.0	20.6	25

LEGEND

- HACR — Heating, Air Conditioning, and Refrigeration
- Hp — Horsepower
- FLA — Full Load Amps
- LRA — Locked Rotor Amps
- MOCP — Maximum Overcurrent Protection (HACR breaker)
- RLA — Rated Load Amps



*Unit has two compressors.

Table 3 — Evaporator-Fan Performance

UNIT SIZE 50AH	CFM	EXTERNAL STATIC PRESSURE (in. wg)											
		0.2		0.4		0.6		0.8		1.0		1.2	
		Rpm	Bhp	Rpm	Bhp	Rpm	Bhp	Rpm	Bhp	Rpm	Bhp	Rpm	Bhp
024	900	509	0.11	632	0.14	739	0.19	833	0.24	919	0.30	997	0.37
	800	495	0.07	623	0.12	733	0.17	829	0.22	915	0.28	993	0.34
	700	470	0.06	604	0.10	717	0.14	814	0.19	901	0.25	979	0.31
036	1350	550	0.17	651	0.23	744	0.29	831	0.36	912	0.43	—	—
	1200	526	0.14	635	0.19	734	0.25	825	0.31	908	0.38	986	0.45
	1050	510	0.11	627	0.16	731	0.21	824	0.27	910	0.33	988	0.40
048	1800	607	0.29	685	0.36	760	0.43	832	0.50	902	0.58	—	—
	1600	566	0.22	652	0.28	734	0.35	813	0.42	888	0.49	960	0.56
	1400	537	0.17	632	0.23	722	0.29	806	0.35	886	0.42	962	0.49
060	2250	640	0.44	715	0.52	786	0.61	—	—	—	—	—	—
	2000	588	0.32	670	0.40	747	0.48	819	0.56	889	0.64	—	—
	1750	552	0.24	642	0.31	725	0.38	803	0.46	878	0.53	950	0.61
072	2700	461	0.36	543	0.47	619	0.60	689	0.75	—	—	—	—
	2400	449	0.29	537	0.40	616	0.53	—	—	—	—	—	—
	2100	435	0.24	529	0.34	611	0.47	683	0.61	—	—	—	—
096	3600	555	0.74	618	0.87	680	1.01	—	—	—	—	—	—
	3200	514	0.66	584	0.80	652	0.81	707	0.94	769	1.10	—	—
	2800	448	0.37	552	0.51	626	0.64	695	0.79	759	0.95	818	1.12

LEGEND

- Bhp — Brake Horsepower

NOTES:

1. Refer to Table 1 for evaporator fan motor and drive information.
2. Upgrade 1 Static Motor is required for **boldface** values.
3. Upgrade 2 Static Motor is required for shaded values.

Table 4 — Condenser-Fan Performance

UNIT SIZE 50AH	CFM	EXTERNAL STATIC PRESSURE (in. wg)											
		0.0		0.1		0.2		0.3		0.4		0.5	
		Rpm	Bhp	Rpm	Bhp	Rpm	Bhp	Rpm	Bhp	Rpm	Bhp	Rpm	Bhp
024	1700	247	0.07	255	0.07	262	0.08	269	0.08	277	0.08	284	0.09
036	2000	276	0.11	282	0.11	289	0.12	295	0.12	301	0.12	307	0.13
048	2500	251	0.17	305	0.18	357	0.22	408	0.27	456	0.32	501	0.37
060	3000	287	0.22	334	0.28	378	0.33	421	0.38	464	0.43	505	0.49
072	5200	367	0.68	438	0.89	464	0.98	490	1.07	516	1.16	542	1.25
096	6400	448	1.26	524	1.59	546	1.70	568	1.81	—	—	—	—

LEGEND

Bhp — Brake Horsepower

NOTES:

1. Refer to Table 1 for condenser fan motor and drive information.
2. Upgrade 1 Static Motor is required for **boldface** values.
3. Upgrade 2 Static Motor is required for shaded values.

START-UP

Unit Preparation — Make sure unit has been installed in accordance with installation instructions and applicable codes.

Compressor Mounting — Compressors are internally mounted on rubber-in-shear (RIS) isolators. Do not loosen or remove compressor holddown bolts.

Internal Wiring — Check all electrical connections in unit control boxes and tighten as required.

Refrigerant Service Valves — Each unit system has 2 Schrader-type service ports, one on the suction line and one on the compressor discharge line. Be sure that caps on the ports are tight.

Compressor Rotation — On 50AH036-096, 3-phase units, it is important to be certain compressor is rotating in the proper direction. To determine whether or not compressor is rotating in the proper direction:

1. Connect service gages to suction and discharge pressure fittings.
2. Energize the compressor.
3. The suction pressure should drop and the discharge pressure should rise, as is normal on any start-up.

If the suction pressure does not drop and the discharge pressure does not rise to normal levels:

1. Note that the condenser and evaporator fans may also be rotating in the wrong direction.
2. Turn off power to the unit and tag disconnect.
3. Reverse any two of the unit power leads.
4. Reapply power to the unit; remove tag.
5. Verify correct refrigerant pressures.

The suction and discharge pressure levels should move to their normal start-up levels.

NOTE: When the compressor is rotating in the wrong direction, the unit will sound louder than normal and will not provide cooling.

Cooling — To start unit, turn on main power supply. Set system selector switch at COOL position and fan switch at AUTO. position. Adjust thermostat to a setting below room temperature. Compressor, condenser and evaporator motors start on closure of contactors.

TO SHUT OFF UNIT — Set system selector switch at OFF position or reset thermostat at a position above room temperature.

SERVICE

WARNING

Disconnect all power to the unit before performing maintenance or service. Electrical shock and personal injury could result.

IMPORTANT: If repairs to refrigerant cycle components (e.g., compressor, filter drier, etc.) are required, recover all refrigerant from the system by using both high and low-pressure ports. Then remove base unit from the space.

Filters — Filters are disposable and should be inspected and replaced at regular intervals monthly or as conditions require. They are located in front of the evaporator coil and may be removed by sliding them horizontally out to edge of unit. See Fig. 2-5. No tools are required for installation or removal of filters.

Condenser Coil — The condenser coil is accessible through the side access panel on condenser section, or through side access panel on condenser section. Use a stiff brush when cleaning coil. Be careful not to bend aluminum fins.

Evaporator Coil — The evaporator coil is accessible for cleaning through the side access panel on evaporator section. When necessary, wash coil with a commercial cleaner (Oakite 164) or dishwasher detergent using a pressurized spray canister. Flush coil from return-air duct side and *take care not to get water in ductwork or unit insulation.*

Condensate Drain — Clean and empty drain pan at least once a year to prevent sludge build-up.

Lubrication — Lubrication of the condenser and evaporator motors is not necessary since both are equipped with permanently lubricated bearings. *Do not oil.*

Unit Condenser Motor — All 50AH units contain belt-driven adjustable-pulley fan systems. The unit fan motors are shipped with adjustable pulley at 4 turns open.

Blower Wheel Servicing — In-space servicing is recommended for the evaporator and condenser blowers. Both are removed by loosening and removing the 2 screws (sizes 024-060) or 4 screws (sizes 072 and 096) that hold them in place. In both cases, the entire assembly is then moved outside of the base unit. Once outside, the blower wheel and condenser shaft bearings and/or evaporator motor can be serviced.

Blower Belt Adjustment — Inspect blower belt for wear, proper belt tension, and pulley alignment as conditions require or at the beginning of each heating and air conditioning season.

Make sure that fan shafts and motor shafts are parallel and level. The most common causes of misalignment are nonparallel shafts and improperly located sheaves. Where shafts are not parallel, belts on one side are drawn tighter and pull more than their share of the load. As a result, these belts wear out faster, requiring the entire set to be replaced before it has given maximum service. If misalignment is in the sheave, belts enter and leave the grooves at an angle, causing excessive belt and sheave wear.

SHAFT ALIGNMENT — Check shaft alignment by measuring the distance between the shafts at 3 or more locations. If the distances are equal, then the shafts are parallel.

SHEAVE ALIGNMENT

1. To check the location of the fixed sheaves on the shafts, use a straightedge or a piece of string. If the sheaves are properly aligned, the string will touch them at the points indicated by the arrows in Fig. 9. Rotate each sheave a half revolution to determine whether the sheave is wobbly or the drive shaft is bent. Correct any misalignment.
2. With sheaves aligned, tighten cap screws evenly and progressively.

NOTE: There should be a 1/8-in. to 1/4-in. gap between the mating part hub and the bushing flange. If the gap is closed, the bushing is probably the wrong size.

3. With taper-lock bushed hubs, be sure the bushing bolts are tightened evenly to prevent side-to-side pulley wobble. Check by rotating sheaves and rechecking sheave alignment. When substituting field-supplied sheaves for factory-supplied sheaves, only the motor sheave should be changed.

BELT TENSION ADJUSTMENT — Using a gage, apply 4 lb of force to the center of the belt and adjust the tension until a deflection of 1/64-in. is achieved for every inch of shaft center distance. See Fig. 10.

Ideal belt tension is the lowest value under which belt slip will not occur at peak load conditions.

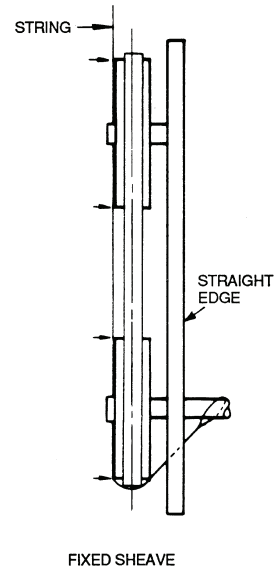

Fig. 9 — Sheave Alignment

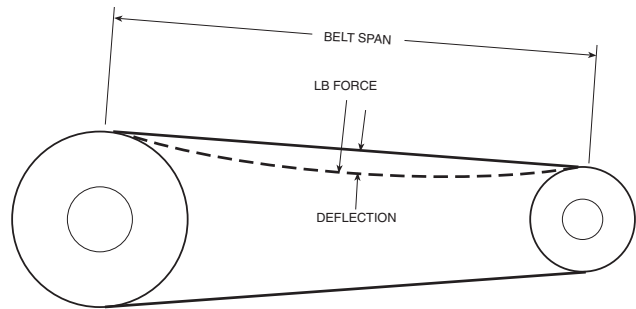

Fig. 10 — Fan Belt Tension

Refrigerant Charge — Unit is shipped fully charged. Amount of refrigerant charge is listed on unit nameplate (also refer to Table 1). Refer to Carrier GTAC II; Module 5; Charging, Recovery, Recycling, and Reclamation manual.

Unit panels must be in place when unit is operating during charging procedure. Unit must operate for at least 10 minutes before adjusting charge. Use standard evacuating techniques. After evacuating system, weigh in the specified amount of refrigerant. (Refer to Table 1.)

